

Sensor solutions for intralogistics

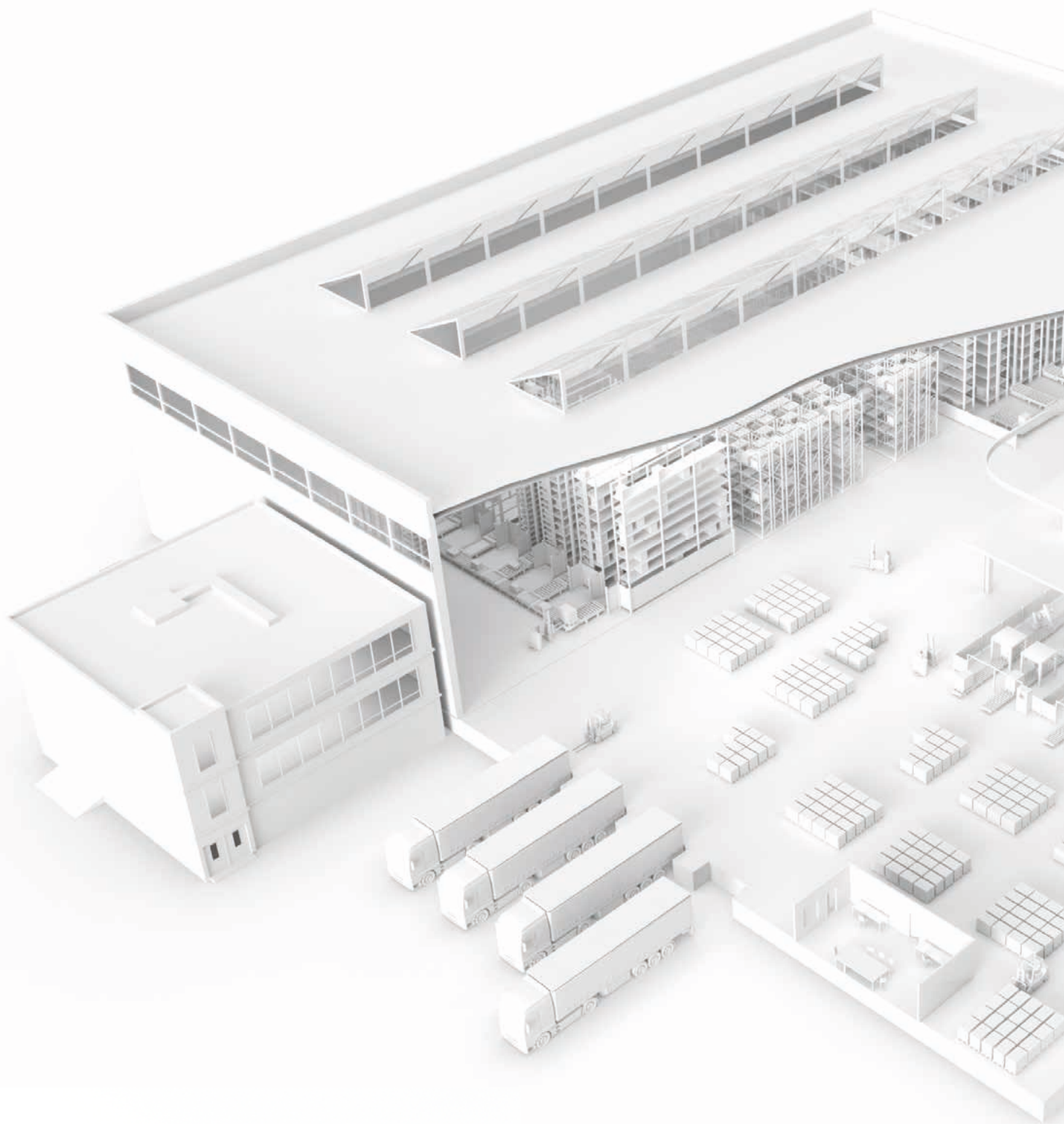

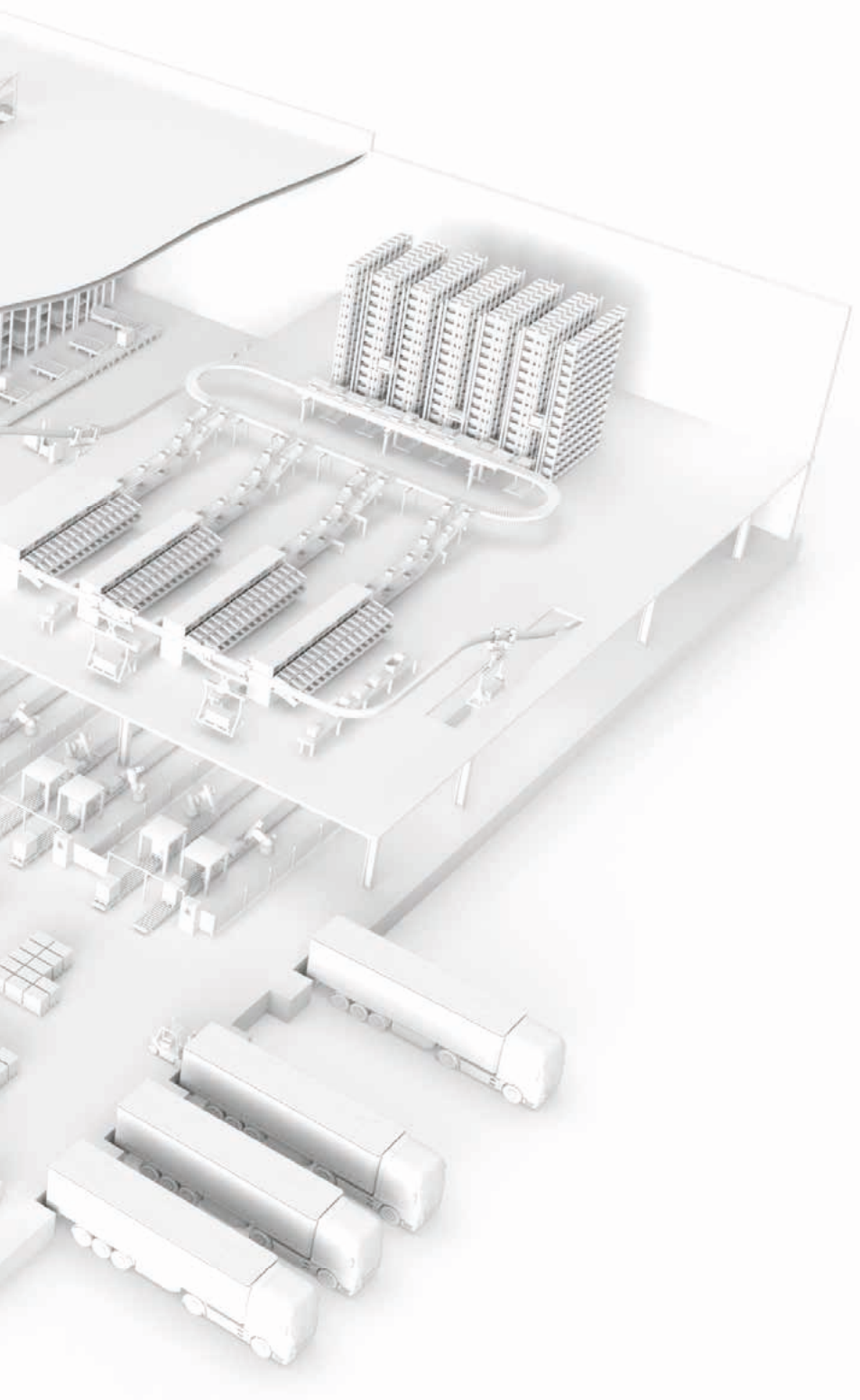



**Future-oriented solutions
for intralogistics**

Page 6–7

Integrated Connectivity

Page 8–9

Stacker cranes

Page 10–15

Shuttles

Page 16–21

Continuous conveyor

Page 22–29

Automated guided vehicles

Page 30–35

Electrical monorail systems

Page 36–39

Cranes

Page 40–43

Side-tracking shelves

Page 44–47

Order picking

Page 48–51

Specifications

Page 52–67

Safety Solutions and Safety Services

Page 68–71

**Accessories and
supplementary products**

Page 72–73

Creating transformation. Yesterday. Today. Tomorrow.

With curiosity and determination, we – the Sensor People – have been partners for technological milestones in industrial automation for 60 years.

The success of our customers is what drives us. Yesterday. Today. Tomorrow.





Future-oriented solutions for intralogistics

As industry experts, we know the application fields of intralogistics with all their specific needs very well. We develop our products specifically with this in mind and thus offer you efficient and future-proof solutions.

Market leaders such as Amazon, Tesco, or Zalando use standards that set the bar. Developments such as “same-day” or “one-hour delivery” require sophisticated logistics and highly automated distribution centers. The basis for this is an intelligent sensor system that works effectively and reliably and thus ensures maximum system availability.

Our 4.0-compatible sensors enable efficient and transparent processes. As the individual sensors become more and more powerful, the number of necessary sensors in a system is often reduced as well. In addition, the sensors check themselves so that downtimes are virtually eliminated. Modern cloud solutions make the process data available worldwide for maintenance and monitoring tasks.





Cost reduction through performance

Our product portfolio is characterized by fast commissioning, intuitive operation, and high performance. Like, for example, the IPS 200i / 400i camera-based sensors for compartment fine positioning in front of single-depth or double-depth racks: their high functionality allows the overall costs of the system to be reduced.



We know your needs

As an industry expert, we have been developing sensor technology specifically for intralogistics for decades. Our proximity to our customers and to the application results in products that are precisely tailored to the needs. For example, our DDLS 500 optical data transceiver. It transmits data at up to 100 Mbit/s, can be easily integrated into the control system via various industrial Ethernet interfaces and alignment is easy with the integrated laser pointer.



Full-service provider for intralogistics

Our claim as intralogistics experts is to offer the right solution for each of your intralogistics applications. Our sensors ensure that your systems operate reliably and safely. And if required, our 24/7 service supports you.

***i*ntegrated connectivity**

For easy interface management

With *i*ntegrated connectivity, our devices can be parameterized directly via the control system, and no additional software effort is required for the transfer of process and diagnostic data. The address within the controller to which the device sends its data is already defined during parameterization. All settings of the devices are stored in the control system. In case of a device exchange, the control automatically transfers these settings to the new device. For easy connection to the fieldbuses used worldwide, our devices offer a wide range of integrated interfaces.

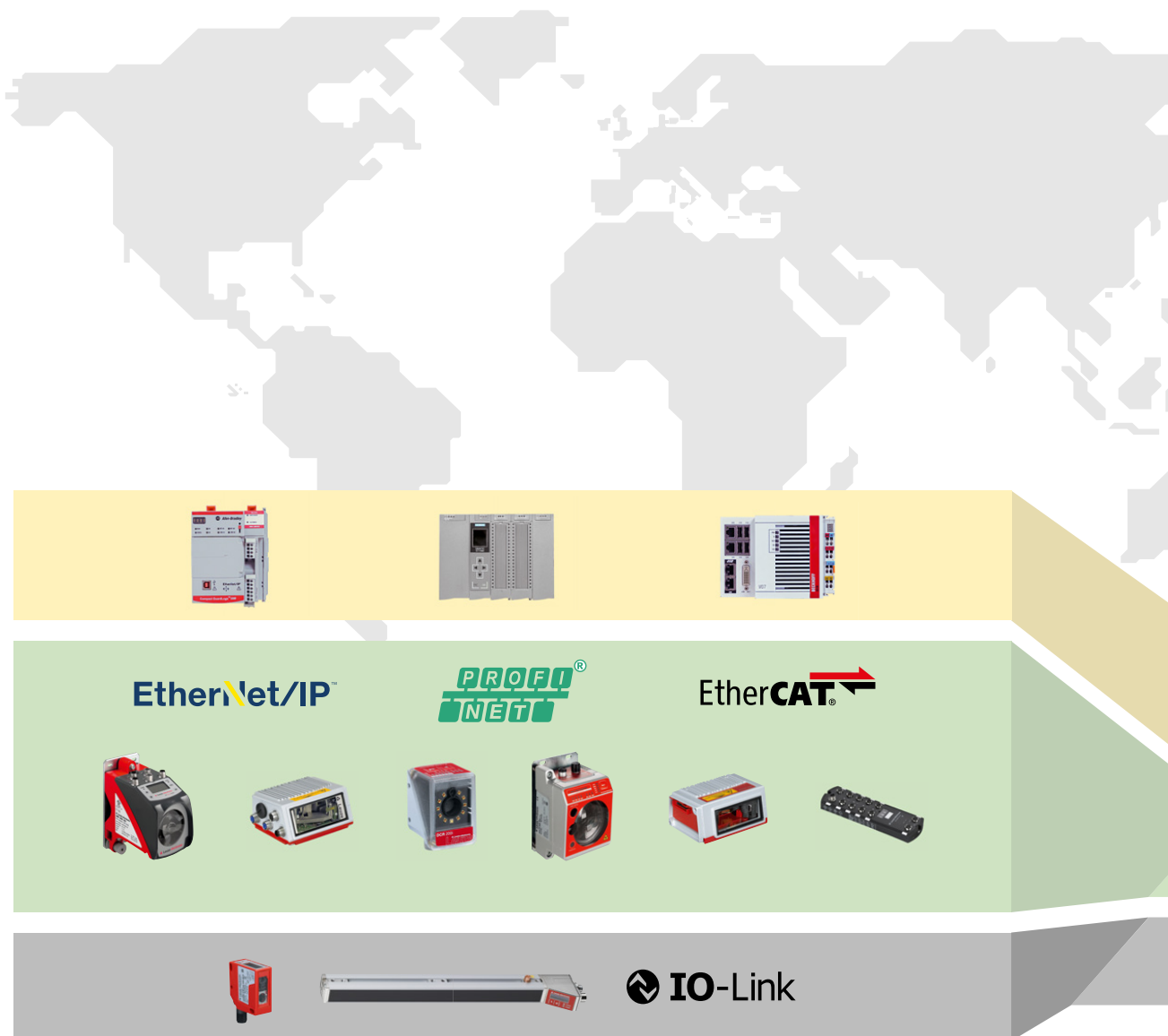

Parallel to the transmission of process data, all relevant diagnostic data can also be retrieved from the control. Alternatively, the display is done via our HTML-based user interface in any internet browser and is independent of the operating system used. The direct transmission of data via OPC/UA to a cloud service is also supported.

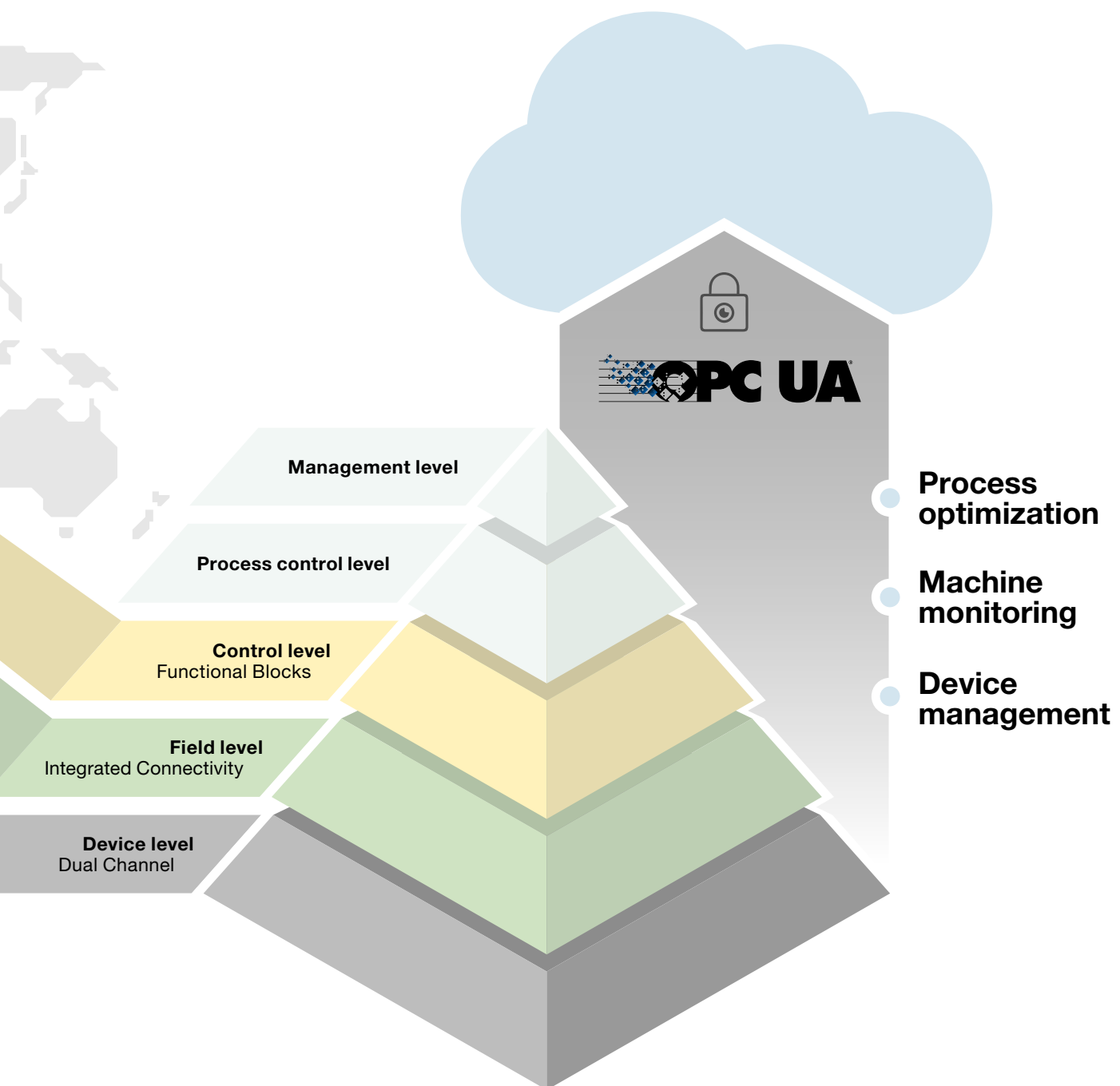

Sensor solutions for stacker cranes

Stacker cranes handle the storage and retrieval of goods in automatic high-bay warehouses. The speed and reliability of the stacker cranes—also in the low temperature range—are decisive for the overall performance and system availability.

The easy alignment of our sensors ensures fast and error-free commissioning. During operation, our sensor solutions ensure the best possible function of the stacker crane. In this way, your throughput can be optimized through dynamic and precise storage and retrieval of goods. Optical compartment occupation checks and push-through protection reliably protect the stored goods and system.



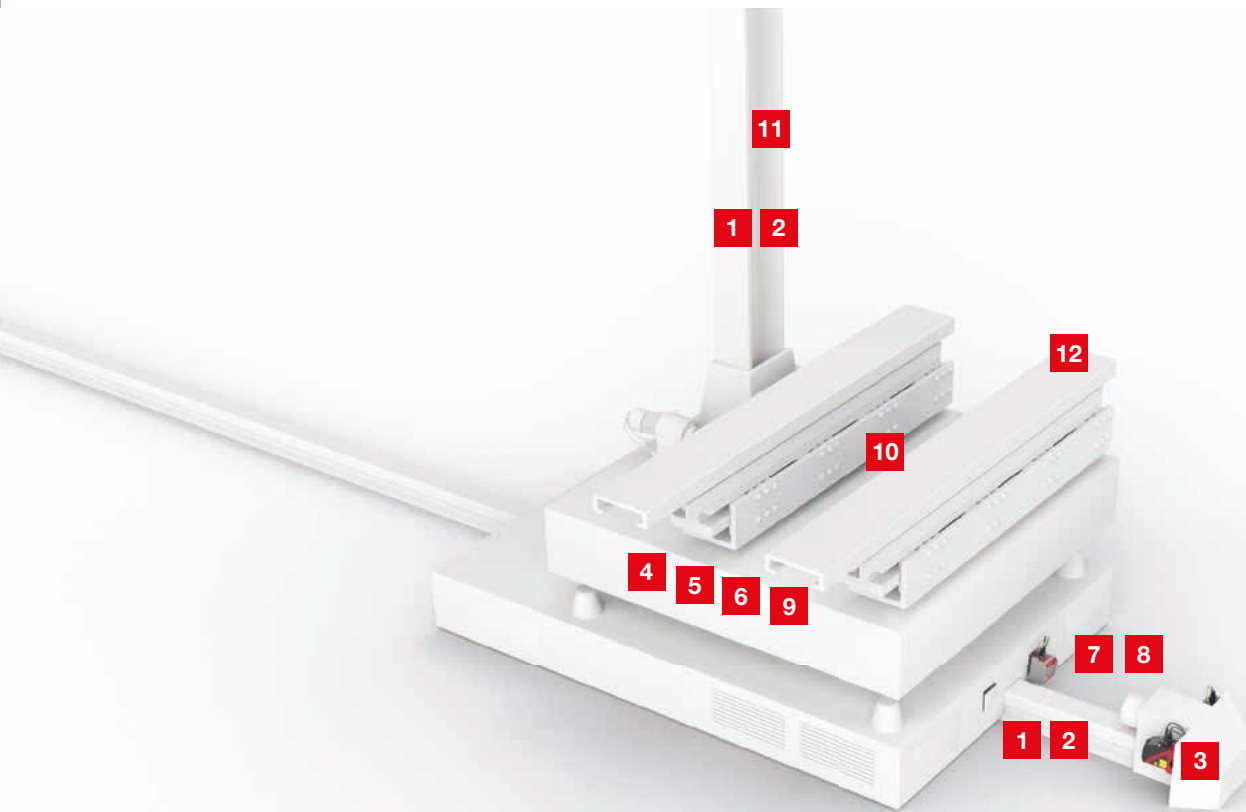

- | | |
|--|--|
| 1 Positioning with bar code positioning system | 7 Optical data transmission up to 2 Mbit/s |
| 2 Safe positioning with bar code positioning system | 8 Optical data transmission up to 100 Mbit/s |
| 3 Positioning with laser positioning system | 9 Compartment occupation check / push-through protection |
| 4 Compartment fine positioning (single-depth) | 10 Presence control |
| 5 Compartment fine positioning with optical sensor (single-depth and double-depth) | 11 Visual monitoring |
| 6 Compartment fine positioning with camera-based sensor (single-depth and double-depth) | 12 Detection of the final position of the load receptacle |

Sensor solutions for stacker cranes

Positioning with bar code positioning system

Requirement: The stacker crane or load receptacle must be positioned in the X-direction (travel axis) and Y-direction (lifting axis) accordingly for the position to be approached.



Solution: The BPS 300i compact bar code positioning systems enable exact positioning. Interfaces for fieldbuses, industrial Ethernet as well as SSI or serial connections make integration in the control simple and flexible. The configuration and diagnosis of the devices are just as easy.

Safe positioning with bar code positioning system

Requirement: The stacker crane or load receptacle must be positioned in the X-direction (travel axis) and Y-direction (lifting axis) accordingly for the position to be approached. Often the risk assessment requires safe position and speed monitoring. For this purpose, safe position detection is necessary.



Solution: With the FBPS 600i safety bar code positioning system, only one sensor is required for safe position detection. The device is connected to a safe evaluation unit – e.g. a frequency inverter – via two SSI interfaces and is suitable for applications up to PL e. This means that safety functions can now be easily implemented.

Positioning with laser positioning system

Requirement: The stacker crane or load receptacle must be positioned in the X-direction (travel axis) and Y-direction (lifting axis) accordingly for the position to be approached.

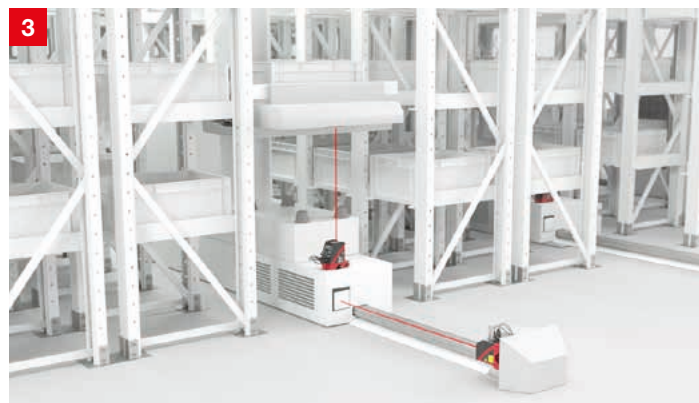

Solution: The AMS 300i laser positioning system quickly determines distances to moving system parts over a distance of up to 300 m with high absolute accuracy. In millisecond intervals, the devices make the measured values available for dynamic control via an extensive selection of industrial Ethernet or fieldbus interfaces.

Compartment fine positioning (single-depth)

Requirement: After the rough positioning of the stacker crane, the compartment fine positioning should take place in the horizontal (X) and vertical (Y) direction. For this purpose, the bar and column edges should be optically sensed at a distance of 100 to 600 mm.

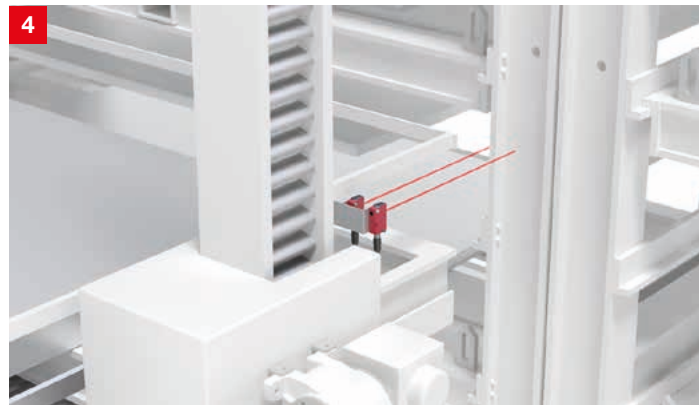

Solution: The HT 25C and HT 46C diffuse reflection sensors with background suppression are used for positioning the load receptacle. A wide range of profile types as well as color or glossy surfaces are reliably detected. Thanks to the optimized beam path, the sensors function reliably even in the case of columns with holes.

Compartment fine positioning with optical sensor (single-depth and double-depth)

Requirement: After the rough positioning of the stacker crane, the compartment fine positioning should take place in the horizontal (X) and vertical (Y) direction. For this purpose, the bar and column edges should be optically sensed at a distance of 100 to 1,900 mm.

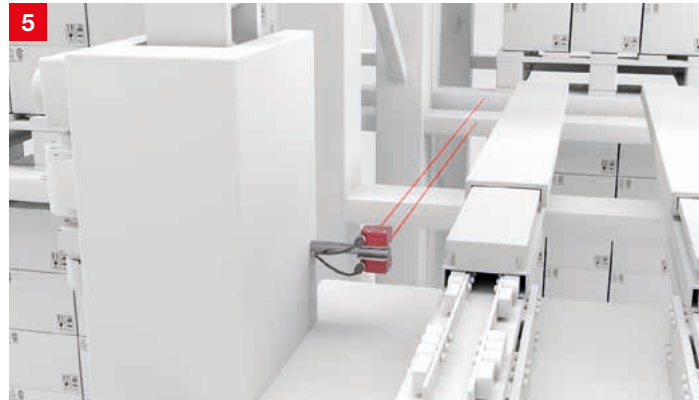

Solution: The HT 110 series diffuse sensors reliably detect different materials even under changeable conditions. They are characterized by precise switching behavior at profile edges. With their operating range of up to 5,000 mm, they are also suitable for use in double-depth storage locations.

Compartment fine positioning with camera-based sensor (single-depth and double-depth)

Requirement: After the rough positioning of the stacker crane, the compartment fine positioning should take place in the horizontal (X) and vertical (Y) direction. For this purpose, the bar or column markings are to be sensed by a camera at a distance of 100 to 1,900 mm.



Solution: The compact IPS 200i/400i camera-based sensors are used for compartment fine positioning in front of single-depth or double-depth racks. Via the integrated Ethernet TCP/IP, PROFINET or Ethernet/IP interface, the devices can be easily integrated into different controls and easily configured via the integrated web server.

Sensor solutions for stacker cranes

Optical data transmission up to 2 Mbit/s

Requirement: Data is to be transmitted wirelessly from fieldbuses such as PROFIBUS, CANopen and Interbus to the stacker crane or the load receptacle. The transmission rate should be up to 2 Mbit/s.

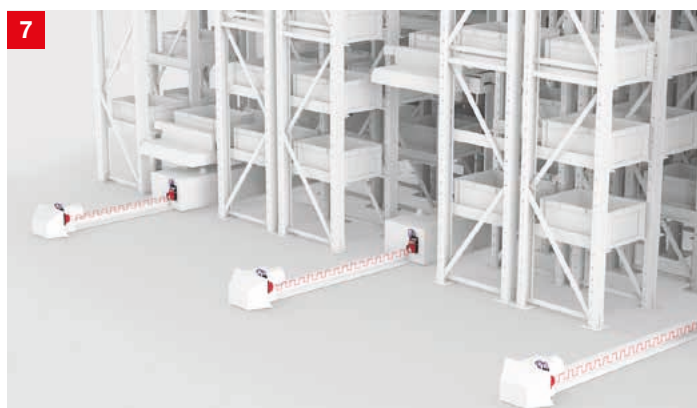

Solution: The DDSL 200 optical data transceiver is available with all common industrial fieldbus interfaces and is therefore easy to integrate into the system. Different operating range models from 80 to 500 m always offer a tailor-made solution.

Optical data transmission up to 100 Mbit/s

Requirement: Data should be transmitted wirelessly from Ethernet-based fieldbuses such as PROFINET, EtherCAT and Ethernet TCP/IP to the stacker crane or the load receptacle. The transmission rate should be designed for data volumes of up to 100 Mbit/s.

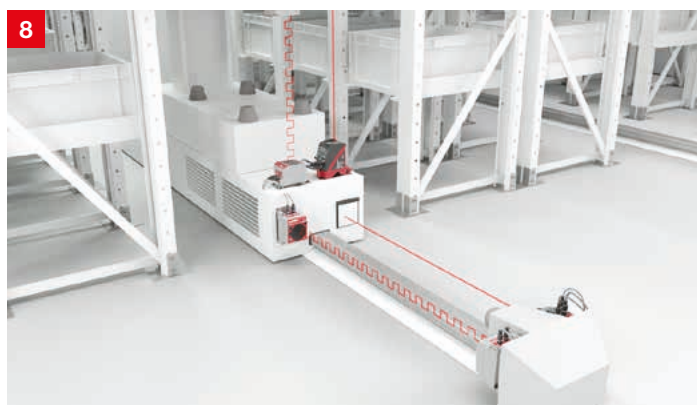

Solution: The DDL5 500 optical data transceiver with industrial Ethernet interfaces transmits data at a rate of up to 100 Mbit/s. The alignment laser and the pre-mounted mounting plate make it particularly easy to align the devices, and the integrated web server ensures fast and location-independent remote diagnosis.

Compartment occupation check / push-through protection

Requirement: Before a pallet or a cassette can be stored in a rack, a check must be performed to determine whether the rack is empty. During retrieval, it must be monitored that the stored material is not pushed through when the telescopic arm or fork is moved.

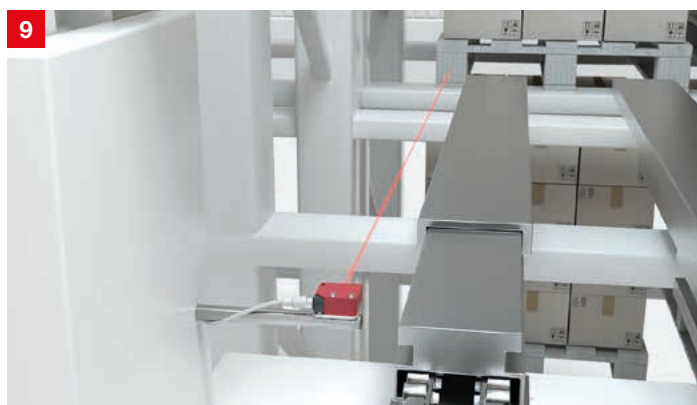

Solution: Thanks to their focused laser, sensors HRT 25B Long Range, ODS/HT 10 and ODS/HT 110 detect the goods at an operating range of up to eight meters and thus offer a high function reserve. With switching product models, the movement of the cassette can be detected with the help of the window function.

Presence control

Requirement: After storage or retrieval, a check must be performed to ensure that the load receptacle has completely unloaded or pulled in the material in order to avoid collisions and downtime.

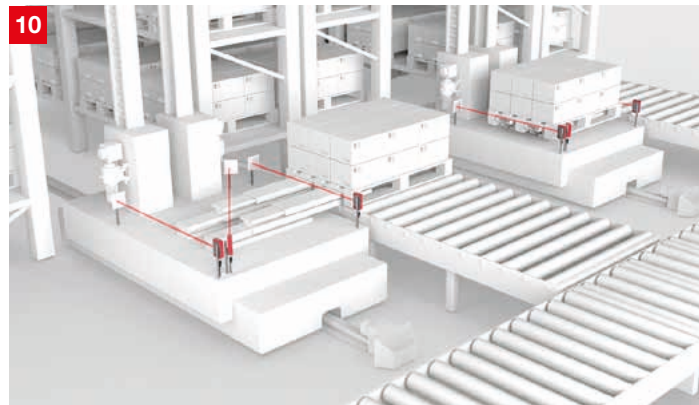

Solution: The optical sensors of the 3C, 25C and 46C series are characterized not only by their long operating range and increased function reserve, but also by their easy handling. With their different optics models, the devices stand for reliable object detection—e.g. even with shrink-wrapped or perforated packages.

Visual monitoring

Requirement: In order to be able to make a visual diagnosis of the stacker crane and load receptacle without having to be on site in person, a camera is needed directly on site.



Solution: The industrial IP camera LCAM 308 offers insights into areas which are not accessible by plant operators. This simplifies troubleshooting in case of failure. The robust camera delivers live streams at high image quality due to its Ethernet interface. In addition, the recording of the last minute can be retrieved.

Detection of the final position of the load receptacle

Requirement: Before the stacker crane is allowed to move, it must be checked whether the load receptacle is in the final position.



Solution: The inductive sensors of the IS 208 and IS 212 series reliably detect metal objects. The devices with robust metal housing can be optimally adapted to the respective application by selecting the switching output, the connection and the operating range.

Sensor solutions for shuttles

Shuttles are compact warehouse vehicles for automatic operation of high-bay warehouses. They are used in parallel and move largely independently in the rack construction. The dynamic shuttles are tasked with transporting the goods safely, reliably identify open spaces, and avoid collisions.

Our sensors are optimized for this area of application and assume tasks in the compartment fine positioning, compartment occupation check and presence control. Sensors switching within milliseconds ensure optimum positioning. Even in low vehicles, our space-saving sensors can be easily integrated, allowing flexible design. All our sensors are designed to be user-friendly, ensuring fast mounting and commissioning.



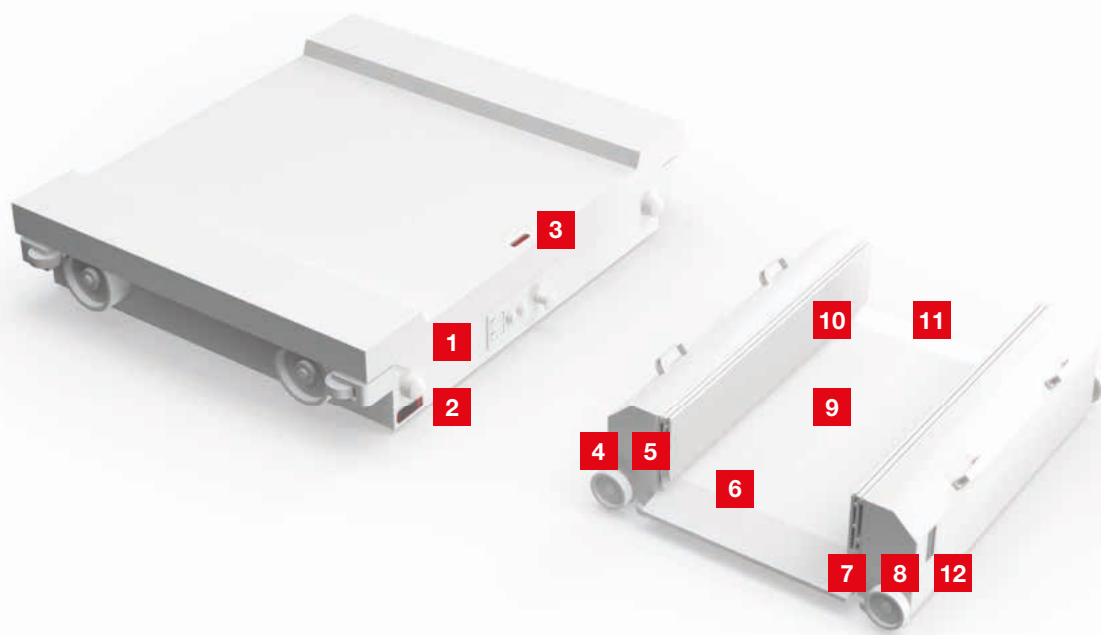

- 1 Positioning of the pallet
- 2 Positioning of the shuttle at the aisle end
- 3 Presence/position control of the pallet
- 4 Collision protection
- 5 Referencing
- 6 Monitoring of projection and overhang
- 7 Compartment occupation check—single-depth
- 8 Compartment occupation check—multi-depth
- 9 Monitoring of container position on the shuttle
- 10 Detection of the final position of the finger
- 11 Detection of the final position of the telescopic fork
- 12 Compartment fine positioning

Sensor solutions for shuttles

Positioning of the pallet

Requirement: To ensure a defined distance between the pallets, the distance between the shuttle and the stored pallet must be precisely determined regardless of surfaces, colors or angles.

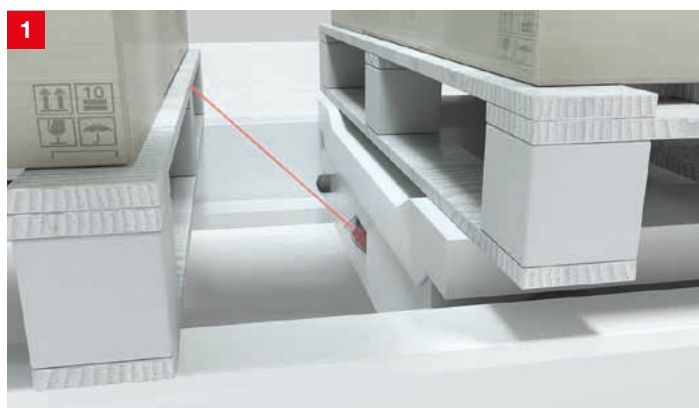

Solution: The ODS 110 and HT 110 measuring or switching distance sensors determine the distance against a non-cooperating target and provide the information as a measured value or as a switching output. With an operating range of up to 5,000 mm, the devices offer an accuracy of typ. ± 15 mm.

Positioning of the shuttle at the aisle end

Requirement: The first pallet in an aisle should always be placed at a defined distance from the aisle end. To do this, the position of the shuttle at the aisle end must be determined.

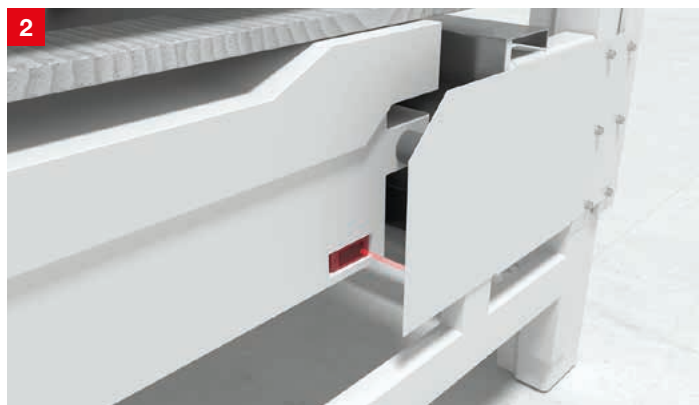

Solution: The ODS 110/ HT 110 measuring or switching distance sensors operate according to the time-of-flight principle (TOF) and offer reliable results over distances of up to 3 m. All devices are equipped with an IO-Link interface. With the HT 110, two switching outputs can be set independently of position.

Presence / position control of the pallet

Requirement: After transferring the pallet on the shuttle, it must be checked whether the pallet has been placed correctly. For this purpose, the presence of the pallet is to be checked at one or more defined positions on the shuttle.



Solution: The HT 3C optical sensors reliably detect pallets thanks to active background suppression and ambient light sensitivity. The HT 3C series offers robust solutions, e.g. for the detection of objects with colored structure, objects with openings or highly polished surfaces.

Collision protection

Requirement: If several shuttles are moving within one level, it must be checked whether the transportation path is free, another shuttle is nearby or the aisle end has been reached.

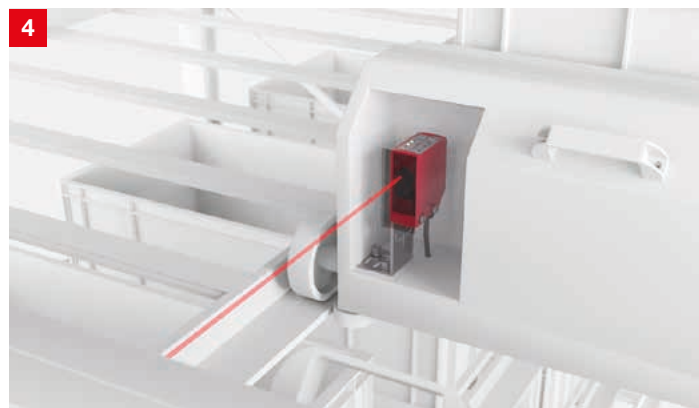

Solution: The ODS 10 distance sensor measures the distance against a non-cooperating target made of any material. Over distances of up to 8 m, the devices provide reliable results with an accuracy of typ. ± 15 mm.

Referencing

Requirement: To counteract slippage, the container should be referenced to a position at the end of the transportation path or at the transfer station. For exact referencing, the sensors used should have an accurate and reproducible switching point.

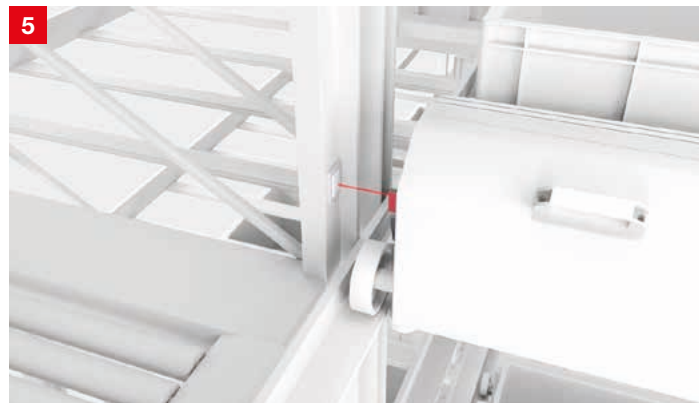

Solution: The PRK 3C optical sensors operate according to the reflection principle. Special versions with high switching frequency and small light spot ensure an exact switching point.

Monitoring of projection and overhang

Requirement: Before the shuttle starts moving, it must be checked that the load has been completely picked up or unloaded and that there is no overhang.

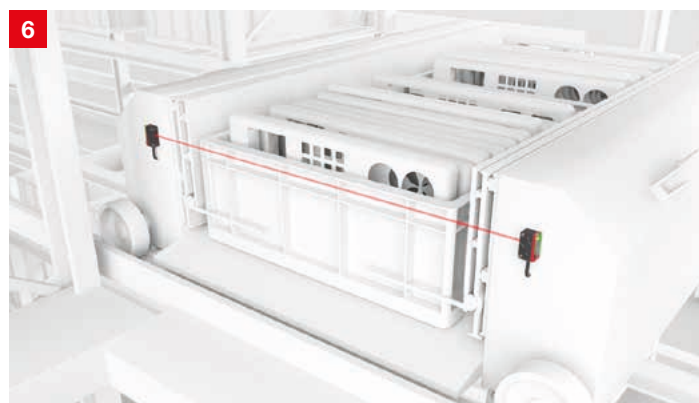

Solution: With their compact cubic construction, the 5 series optical sensors are used for powerful and cost-optimized standard detection tasks. The integrated M3 metal threaded sleeves and the flexible cable outlet downwards or to the rear simplify installation even in situations with limited installation space.

Sensor solutions for shuttles

Compartment occupation check—single-depth

Requirement: Before a container or carton can be stored, it must be checked whether the space is free.

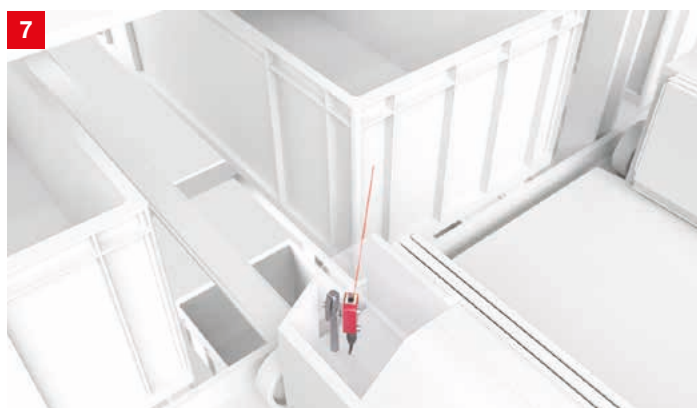

Solution: The 3C series scanning sensors reliably detect objects against a background. Even objects with colored structure are reliably detected.

Compartment occupation check—multi-depth

Requirement: Before a container or carton can be stored, it must be checked whether the space is free.



Solution: The series 25C scanning sensors reliably detect objects against a background. Even objects with colored structure are reliably detected. For applications with operating ranges of more than 2 m, the particularly powerful long-range model is available.

Monitoring of container position on the shuttle

Requirement: It should be determined in which area of the shuttle a container or carton is located.



Solution: With their compact cubic construction, the 5 series optical sensors are used for powerful and cost-optimized standard detection tasks. The integrated M3 metal threaded sleeves and the flexible cable outlet downwards or to the rear simplify installation even in situations with limited installation space.

Detection of the final position of the finger

Requirement: The final position of the finger must be checked to ensure correct storage and retrieval.



Solution: The inductive sensors of the IS 208 series reliably detect metal objects. The small standard devices with a diameter of only 8 mm and robust metal housing can be easily and individually integrated into the shuttle.

Detection of the final position of the telescopic fork

Requirement: Before the shuttle moves, it must be ensured that the telescopic fork is fully retracted. For this purpose, check the final position of the telescopic fork.



Solution: These IS 288 series inductive switches can be used for various detection tasks. The devices with cubic constructions are available with plastic and metal housings. With its laterally aligned sensor field, space and cost-saving integration is possible.

Compartment fine positioning

Requirement: For exact positioning of the shuttle, hole markings are made in the guide rail. These are to be detected in a reproducible manner.



Solution: The powerful 3C series diffuse sensors with background suppression reliably detect objects against a wide variety of backgrounds. Models with laser light are available for particularly precise and fast positioning applications.

Sensor solutions for continuous conveyors

Continuous conveyors ensure the continuous flow of goods. For reliable operation of the systems, the presence of pallets and containers must be detected, dimensions and fill levels controlled, and bar codes reliably read. This guarantees a seamless production process.

Our extensive sensor product range offers reliable and fast object detection. It also protects people and the system. Individually deployable reading principles, such as bar code, 2D-code, and RFID guarantee maximum flexibility. With their high performance reserve, our sensors offer reliable detection even with glossy, dark or stretch-wrapped packages, and rough environmental conditions. Thanks to the intelligent mounting technology, easy alignment and simple integration into existing systems via fieldbus interfaces such as PROFINET, our sensors can also be quickly put into service.



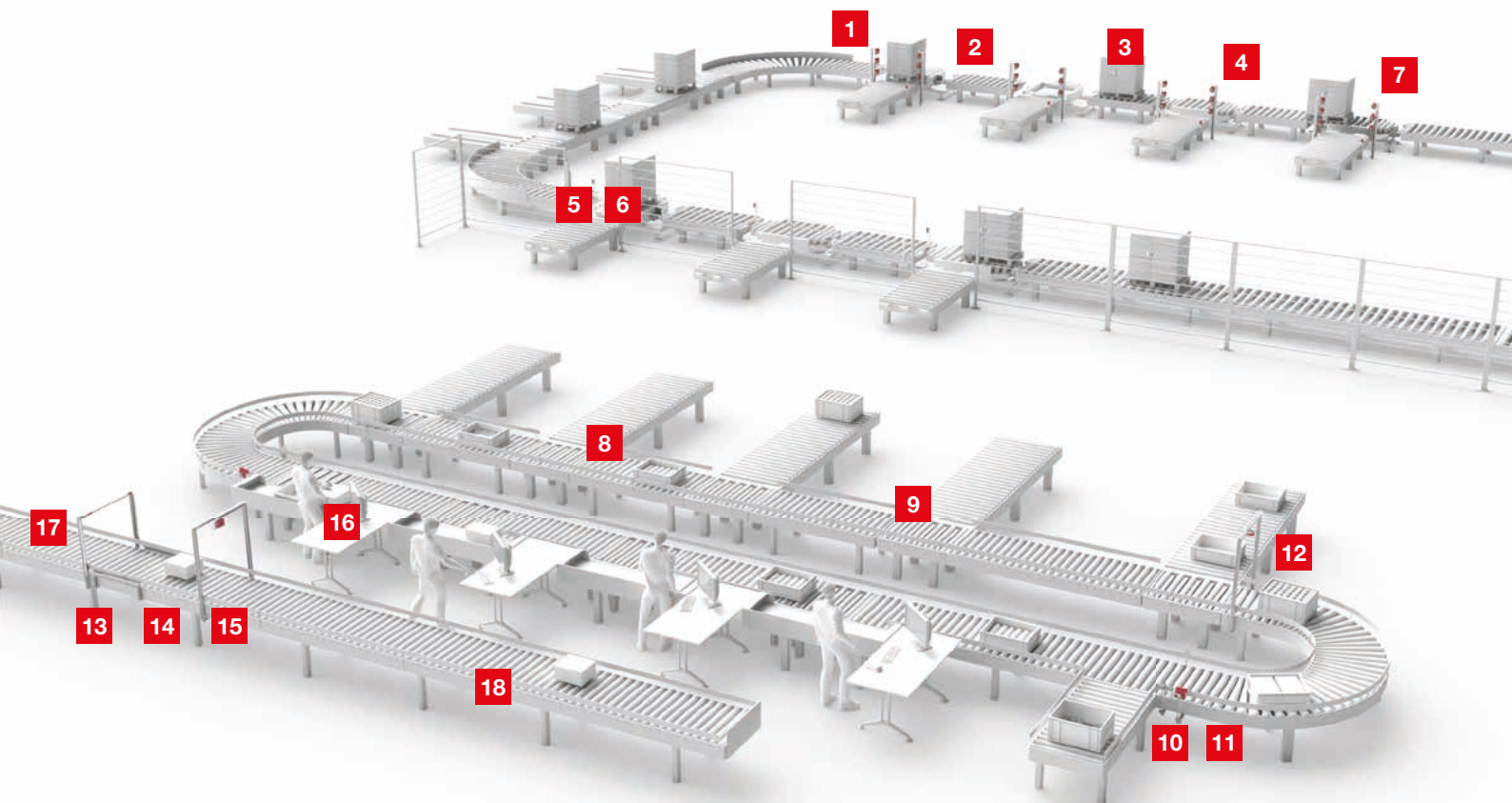

- | | |
|--|--|
| 1 Detection of shrink-wrapped objects | 11 Identification of containers |
| 2 Detection of pallets | 12 Check "container empty" |
| 3 Detection of pallets from below | 13 Code reading of codes printed directly on the carton |
| 4 Width and height monitoring | 14 Code reading on the top of aligned cartons |
| 5 Access guarding with muting | 15 Code reading on the top of unaligned cartons |
| 6 Access guarding with Smart Process Gating | 16 Manual code reading |
| 7 Code reading on the pallet | 17 Contour check |
| 8 Detection of containers and trays | 18 Detection of polybags |
| 9 Detection of the closing state of flaps | |
| 10 Code reading on containers and trays | |

Sensor solutions for continuous conveyors

Detection of shrink-wrapped pallets

Requirement: The film-wrapped or shrink-wrapped pallets should be reliably detected over the entire length. The output signal of the sensor used must not show any fluctuations.

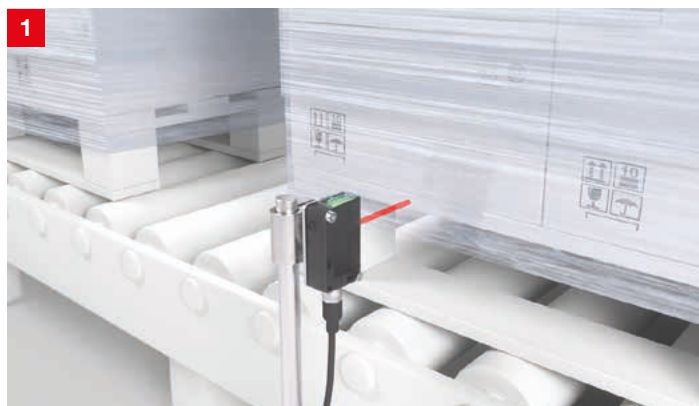

Solution: The PRK 46C.D and PRK 25C.D retro-reflective photoelectric sensors are optimized for use on roller conveyors. It offers high functional reliability especially for film-wrapped and shrink-wrapped pallets. Thus, the sensor generates a stable output signal as long as the object is within the detection range.

Detection of pallets

Requirement: All types of pallets should be reliably detected over the entire length. Defective pallets or openings on pallets should also be allowed.

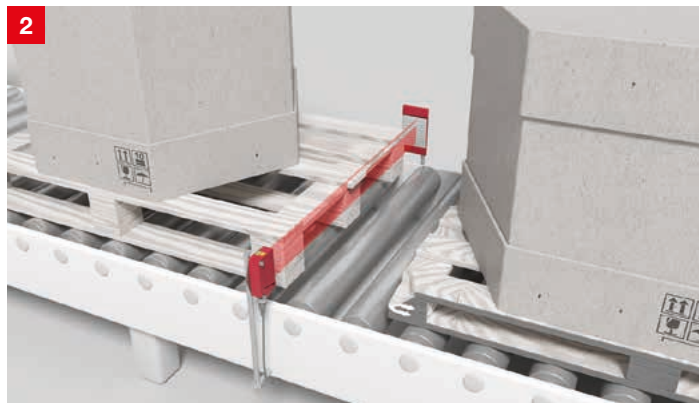

Solution: The RK 46C retro-reflective photoelectric sensors also reliably detect objects with irregular shapes and openings. For this purpose, the devices use a powerful, 60 mm wide light-band.

Detection of pallets from below

Requirement: Different types of pallets run over a conveyor system, which should be reliably detected from below. High-frequency hall lighting and dirt particles must not affect the sensor. In addition, the sensors should not require any additional work during the installation of the conveyor line.



Solution: The HT 25C series diffuse sensors are already mounted by the conveyor system manufacturer in the interior of the conveyor by means of a special holder. This has an integrated front screen for the discharge of dirt particles. The special ambient light parameterization of the sensors efficiently suppresses ambient light sources.

Width and height monitoring

Requirement: Before a pallet can be fed into the conveyor system or storage system, the dimensions of the loaded pallet must be checked.

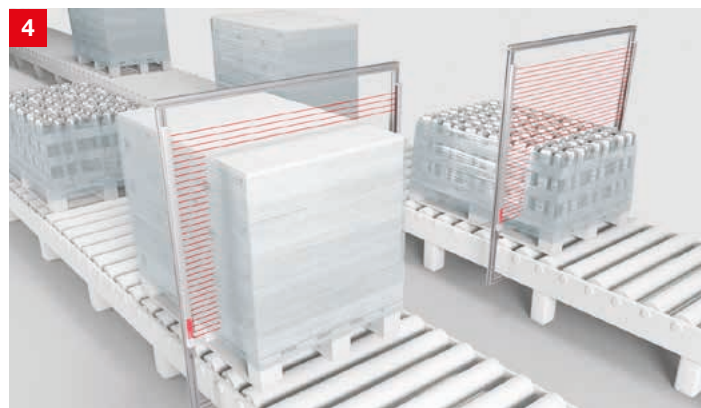

Solution: The CSL 710 switching light curtains check the dimensions of the loaded pallet. Different resolutions and measuring field lengths as well as 4 configurable inputs / outputs allow the devices to be optimally adapted to the application and easily aligned thanks to the integrated display.

Access guarding with muting

Requirement: Access guarding on the conveyor line is to prevent persons from accessing the danger zone, while at the same time allowing the transported goods to pass through.

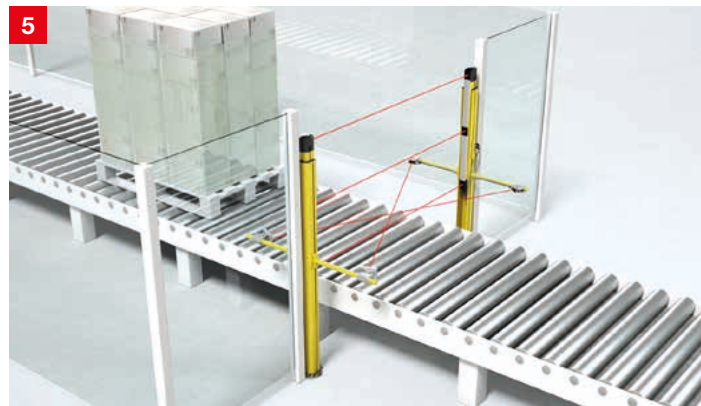

Solution: The muting function bridges the safety sensor in a controlled manner to allow the transported goods to pass through. This function is already integrated in the MLD 300/500 multiple light beam safety devices and the MLC 500 safety light curtains.

Access guarding with Smart Process Gating

Requirement: Access guarding on the conveyor line is to prevent persons from accessing the danger zone, while at the same time allowing the transported goods to pass through. At the same time, the safety technology should take up as little space as possible.

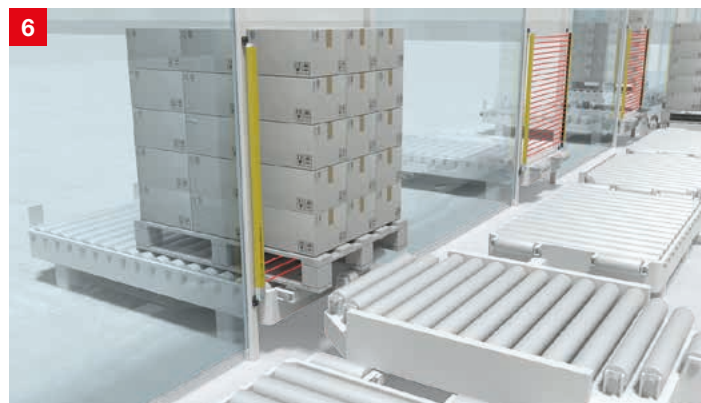

Solution: With Smart Process Gating, the safety sensor is bridged by means of a control signal from the PLC. The function is integrated in the MLC 530 SPG safety light curtain. Additional muting sensors are not required and, owing to SPG, the systems have low space requirements.

Sensor solutions for continuous conveyors

Code reading on the pallet

Requirement: During goods receipt or goods issue, the goods code should be read in and transferred to the higher-level system. The position of the label can vary.



Solution: Several bar code readers of the BCL 500i / 600i series are used to read the code label in varying positions. Via the integrated switch, the devices can be connected to each other as well as directly to the control via a line structure.

Detection of containers and trays

Requirement: A container or tray should be reliably detected as it passes by. The sensors used should be easy to mount and connect.

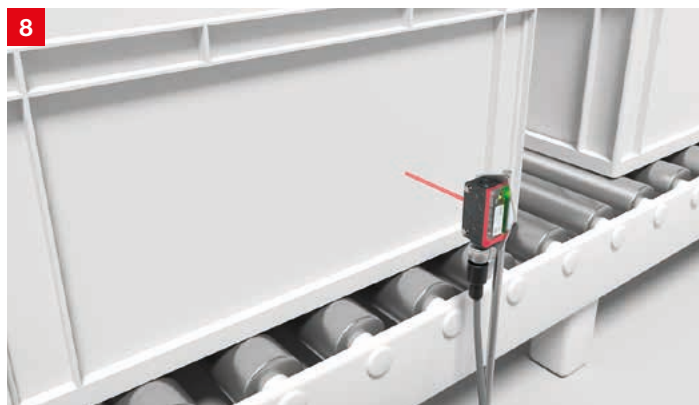

Solution: With their compact cubic construction, the 5 series optical sensors are used for powerful and cost-optimized standard detection tasks. The integrated M3 metal threaded sleeves and the flexible cable outlet downwards or to the rear simplify installation even in situations with limited installation space.

Detection of the closing state of flaps

Requirement: To stop the containers, the closing state of the flap must be checked.



Solution: The IS 244 series inductive sensors detect the closing state of the flap. Versions with M12 connector or comfortable terminal compartment are available for the connection.

Code reading on containers and trays

Requirement: The bar codes attached to the containers or trays should be read and the information transferred to the control via a fieldbus. It must also be possible to mount the code reader between conveyor lines.

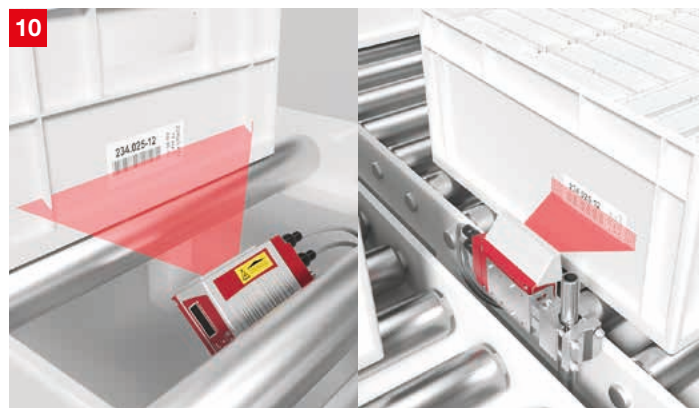

Solution: The bar code readers of the BCL 200i and BCL 300i series can be mounted at a short distance from the code due to their minimal reading distance of only 40 and 20 mm. With its integrated switch, line structures can be set up in all Ethernet-based fieldbuses. The parameters are set via the control.

Identification of containers

Requirement: In harsh or soiled environments, the containers should be identified.



Solution: The RFM 32 and RFM 62 RFID read/write devices read the information from the RFID transponders attached to the containers. Contactless RFID technology works reliably even in soiled environments. With reading distances of up to 400 mm, the readers can be integrated very flexibly into the conveyor system.

Check “container empty”

Requirement: To use a container again, it must be checked whether there are still objects in the container.

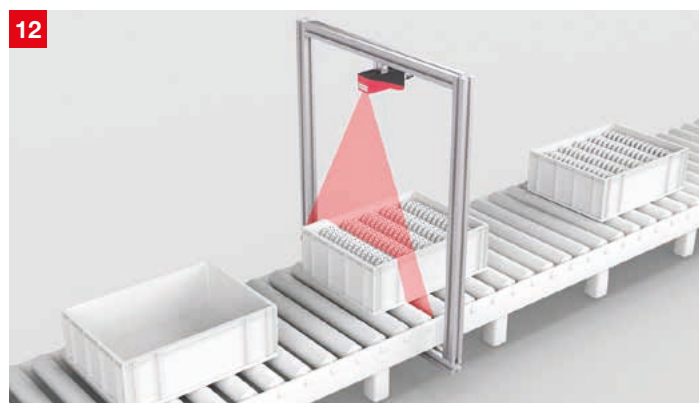

Solution: The LRS 36 light section sensors use a laser line for sensing object detection. Thus, the presence of objects in the container can be reliably determined.

Sensor solutions for continuous conveyors

Code reading of codes printed directly on the carton

Requirement: A bar code printed directly on the carton should be read. The read information must then be transferred to a control.

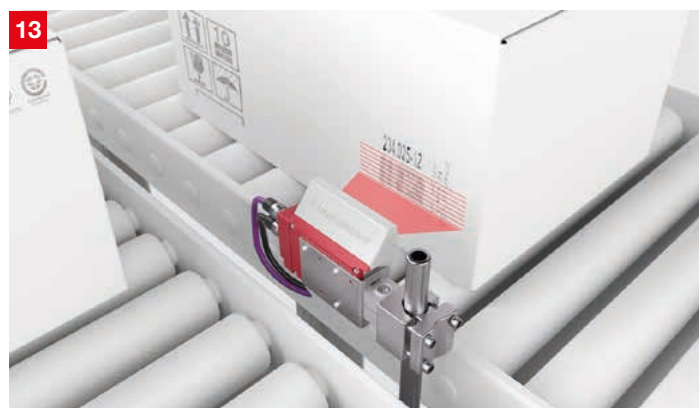

Solution: The BCL 300i series bar code readers with special optics for ink jet-printed codes read the codes on the cartons. The integrated switch makes it easy to integrate the devices into line structures of Ethernet-based fieldbuses. The parameters are set via the control.

Code reading on the top of aligned cartons

Requirement: When goods are dispatched from mail order and e-commerce, the bar code on the shipping labels should be read. The aligned cartons usually differ significantly in their dimensions. The read information should be transferred to a control.

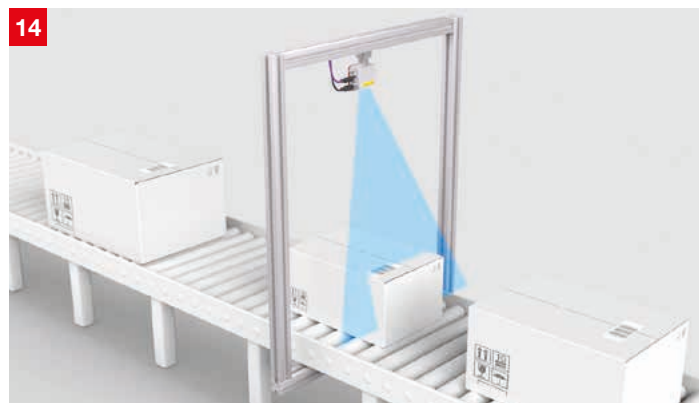

Solution: The BCL 600i series bar code readers read the codes on cartons from above. They work with blue laser light for more depth of field at small modulus widths and thus do not require expensive focus adjustment. The devices can be easily integrated into the control via the integrated fieldbus interfaces.

Code reading on the top of unaligned cartons

Requirement: When goods are dispatched from mail order and e-commerce, the bar code on the shipping labels should be read. In this case, the non-guided cartons usually differ significantly in their dimensions and orientation. The read information should be transferred to a control.



Solution: The MSPi modular scanner portal uses at least two aligned bar code readers for reading unaligned bar codes. If required, we also offer portal configurations tailored to your application. The portals can be easily integrated into the control via the integrated fieldbus interface.

Manual code reading

Requirement: During order picking, the goods codes should be read and transferred to the goods management system.



Solution: The IT 1472Xg series mobile bar code readers read all bar codes commonly used in warehousing and logistics. Depending on the application, versions with cable connection or radio transmission are available.

Contour check

Requirement: The carton transported on the conveyor system is to be gripped automatically for palletizing. In another application, it should be detected whether the carton is intact and closed. For both applications, the contour of the carton must be checked.

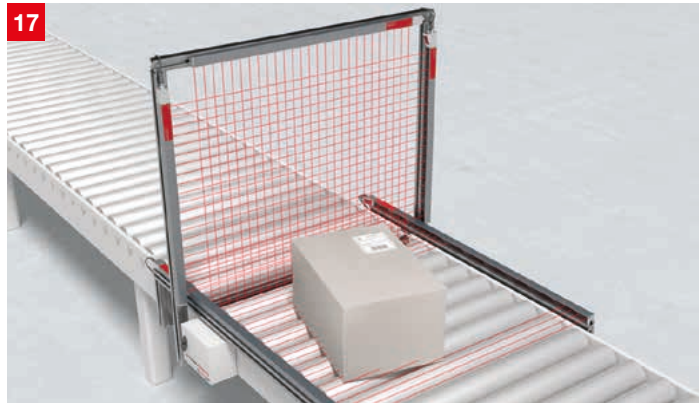

Solution: The CMS 700i 3D contour measurement system detects the length, width, height, protrusions, deformations and position of any objects as they pass by, independent of their shape and surface structure. Even polybags are reliably detected. The complete system includes all components for installation and operation under one article number.

Detection of polybags

Requirement: On a belt conveyor, polybags should be reliably detected along their entire length at a speed of up to 2.5 m/s.

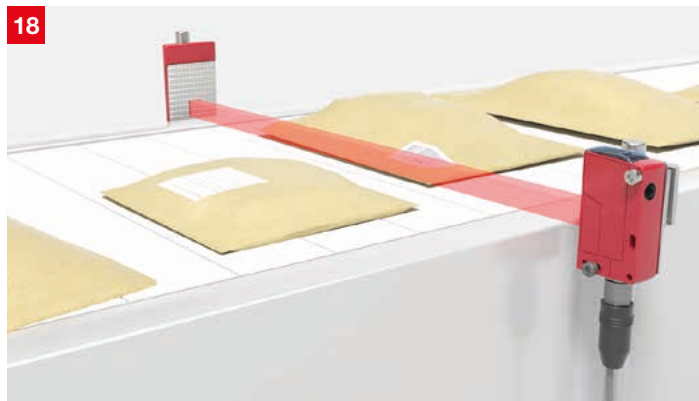

Solution: The RK 46C series retro-reflective photoelectric sensors reliably detect objects as small as 5 mm on a belt conveyor system. For this purpose, the devices use a 25 mm wide, powerful light-band. Due to the high switching frequency of 250 Hz, the RK 46C detects objects even at high conveyor speeds.

Sensor solutions for automated guided vehicles (AGV)

Automated guided vehicles move goods from A to B. The paths can be easily adapted. This makes the production system very flexible. The demands on dynamics and safety are high. Especially when several vehicles are used at the same time.

Intelligent sensor solutions are a prerequisite for smooth operation and to prevent collisions. Safety laser scanners safeguard the vehicles. Our high-resolution and dynamic sensors provide the data for the precise navigation of the AGVs. The correct pick-up and transfer of goods is monitored by optical and inductive sensors.





- 1 Safeguarding the transportation path
- 2 Safeguarding the transportation path and navigation
- 3 Vertical positioning of the load receptacle
- 4 End positioning of load receptacle
- 5 Detection of the final position of the load receptacle
- 6 Determining the position of the pallet on the load receptacle

- 7 Detection of the shelf rack for compartment fine positioning
- 8 2D-code reading for grid navigation
- 9 Optical guidance
- 10 Conveyor control
- 11 Presence control of transport material
- 12 Fine positioning for material transfer

Sensor solutions for automated guided vehicles

Safeguarding the transportation path

Requirement: To safely stop the AGV in the presence of persons or objects, a defined area in front of the AGV must be monitored. To adapt to speed and transportation path, the size and direction of the area should be switchable.

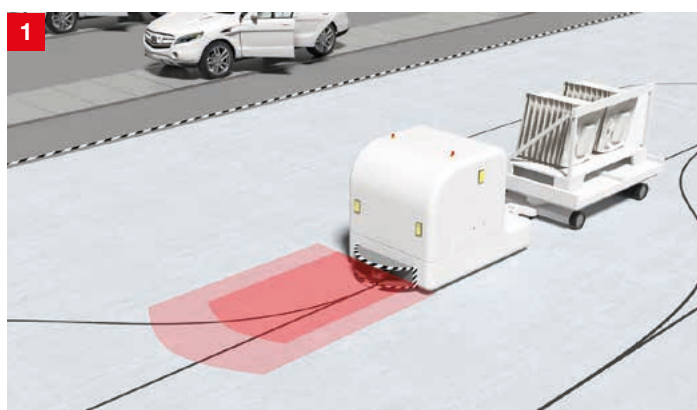

Solution: The RSL 400 safety laser scanner has a scanning range of 270° and up to 100 switchable field pairs. This allows the protective field to be optimally adapted to the speed and the transportation path.

Safeguarding the transportation path and navigation

Requirement: If the principle of natural navigation is used, the safety sensor should simultaneously provide the measurement data for the navigation software in addition to safeguarding the transportation path in different driving situations.

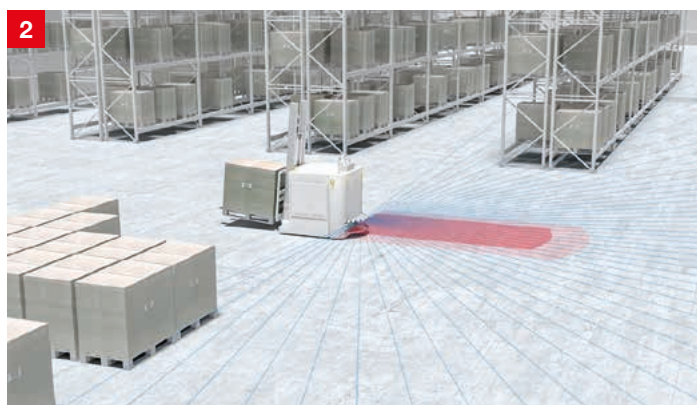

Solution: The RSL 400 safety laser scanner merges safety technology and high-quality measurement value output in a single device. It has up to 100 switchable field pairs. The measurement data have a high angular resolution of 0.1°, which allows a very accurate map of the environment to be created.

Vertical positioning of the load receptacle

Requirement: For reliable storage and retrieval of the pallet, the load receptacle must be positioned precisely and repeatably at the correct height.



Solution: The AMS 300i laser positioning system supplies measurement data every 2 ms with an absolute accuracy of ± 2 mm. The data can be transferred to the control via a wide range of interfaces.

End positioning of load receptacle

Requirement: In order to detect the pallet with the load receptacle, it must be detected where the spaces of the pallet feet are located and whether they are freely accessible.

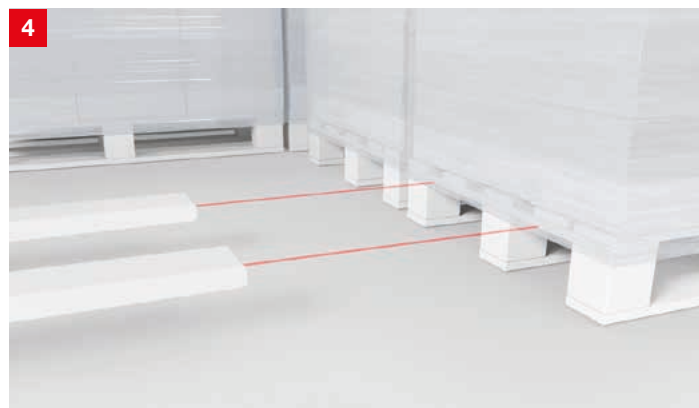

Solution: The HT 3C series diffuse sensors operate independently of the material and have precise switching points. Two digital switching outputs allow the same sensors to be used for compartment fine positioning.

Detection of the final position of the load receptacle

Requirement: Before certain functions of the vehicle can be activated—such as switching from creep speed to normal speed—it must be ensured that the load receptacle is in the final position.



Solution: The IS 212 series inductive sensors detect metal objects with a maximum working distance of 10 mm. The devices are well protected against environmental influences and cleaning processes by the robust metal housing.

Determining the position of the pallet on the load receptacle

Requirement: When picking up the pallet, the distance between the pallet and the end face of the load receptacle must be determined in order to stop the forward movement in good time.



Solution: With their large light spot, the HRT 25B LR series distance sensors determine the distance to objects with a wide variety of colors and surfaces reliably and with repeatable accuracy. Thanks to TOF (time of flight) technology, the devices also have a high operating range of 2,500 mm and a high angle tolerance.

Sensor solutions for automated guided vehicles

Detection of the shelf rack for compartment fine positioning

Requirement: In order to place the pallet safely in the warehouse, the edge of the shelf rack on which the pallet is to be placed must be reliably detected.



Solution: The HT 3C series diffuse sensors operate independently of the material and have precise switching points. Two digital switching outputs allow the same sensors to also be used for positioning the load receptacle.

2D-code reading for grid navigation

Requirement: Labels with 2D-codes are affixed to the floor in a fixed grid. By reading the code and determining the angular position of the code in relation to the sensor, the direction of movement of the AGV should be corrected so that the next 2D-code can be approached.



Solution: The DCR 200i 2D-code reader reads the codes as the AGV passes over them. The large working range of 40–360 mm allows flexible installation in the AGV and ensures stable operation. The integrated set-up wizard makes it quick and easy to put the devices into operation.

Optical guidance

Requirement: For fast and efficient movement, AGVs should follow a defined path marked by a trace placed on the floor. For use in flat vehicles, the sensor used should only require a low installation height.

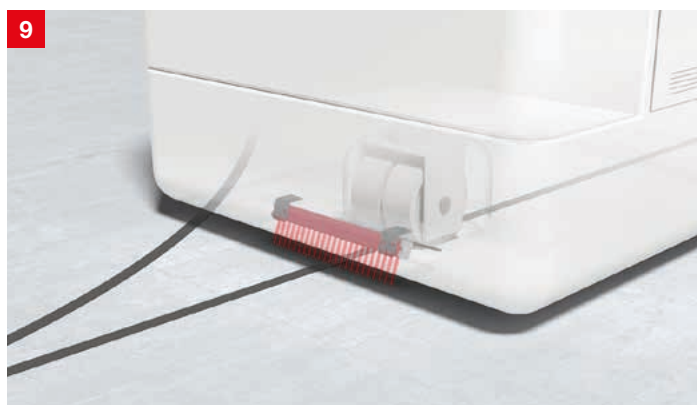

Solution: The OGS 600 optical guidance sensor detects the trace by means of edge detection and sends corresponding signals to the control. The devices work particularly reliably in combination with our optimized OTB trace tapes. Since the minimum distance from the floor is only 10 mm, the OGS 600 can be integrated into the AGV to save space.

Conveyor control

Requirement: The conveyor on the AGV should be activated by the transfer station in the required direction of movement without contact.

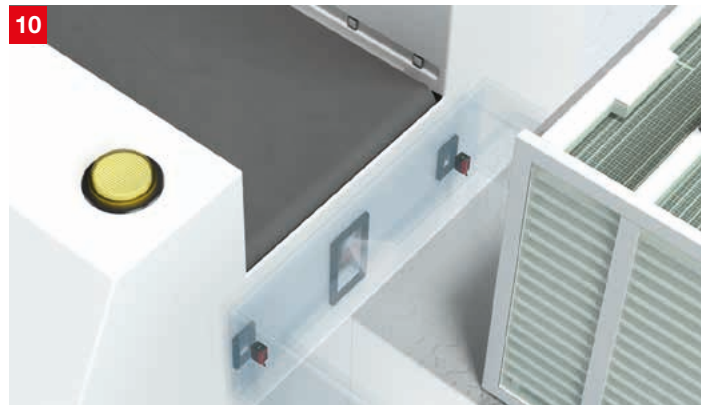

Solution: The cost-effective series 5 throughbeam photoelectric sensors transmit the switching information to the AGV. The devices are insensitive to ambient light and are easy to align thanks to the highly visible red light.

Presence control of transport material

Requirement: It should be checked whether the transport material has been transferred to the AGV completely and without overhang.

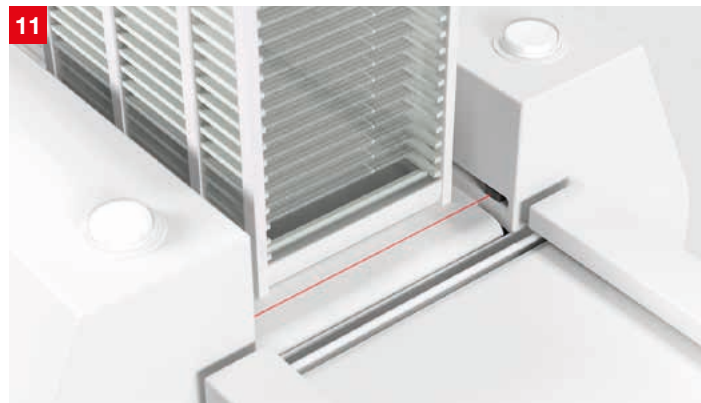

Solution: The cost-effective series 5 retro-reflective photoelectric sensors are easy to integrate with their compact design. Due to the active ambient light suppression, the devices operate particularly reliably.

Fine positioning for material transfer

Requirement: At the transfer station, the transported goods should be transferred without vibration. For this purpose, the AGV and/or the load receptacle must be positioned with millimeter precision.

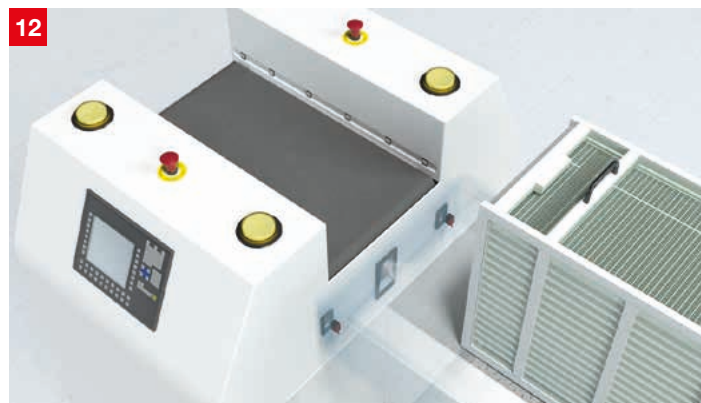

Solution: The IPS 200i smart camera determines its position in relation to a marker (hole or reflector) with an accuracy of up to 0.1 mm. The distance can be up to 600 mm. The results are output via an Ethernet TCP/IP, PROFINET or Ethernet/IP interface.

Sensor solutions for electrical monorail systems

Electrical monorail systems are rail-guided transport systems to transport goods from A to B. They must be flexible to use, precisely position the goods, and ensure an efficient production process.

Our intelligent sensors position with millimeter precision, provide reliable all-round protection and increase the productivity of your system. The bar code positioning system BPS ensures reliable positioning in curves, gradients and track switches. Optical distance sensors guarantee reliable collision protection. Safety laser scanners safeguard danger zones at transfer points. And our powerful identification technologies (bar code / 2D-code / RFID) also increase the productivity of your system.



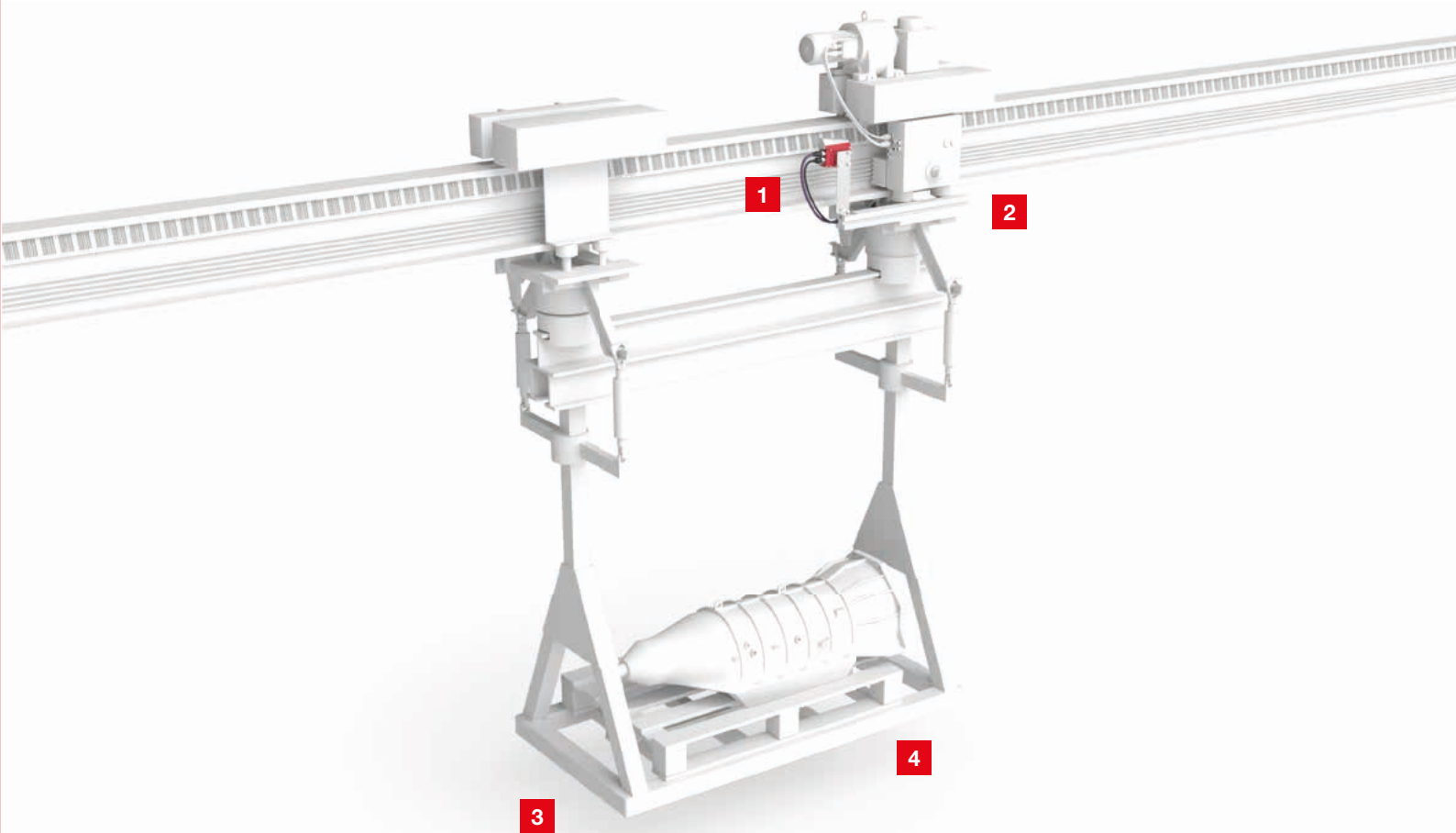

1 Positioning of the transport unit

2 Collision protection

3 Safeguarding the load pick-up / drop-off area

4 Code reading on pallets

Sensor solutions for electrical monorail systems

Positioning of the transport unit

Requirement: For control of the electric monorail system, the position of the transport unit on the carrier must be known with millimeter precision at all times.

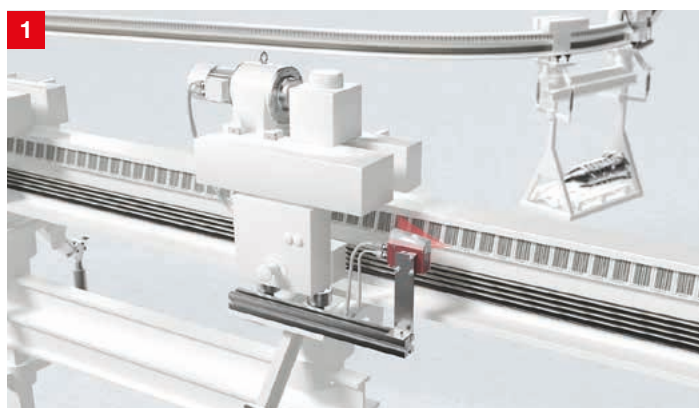

Solution: The compact BPS 8 and BPS 300i bar code positioning systems enable exact positioning over a length of up to 10,000 m. Thanks to a wide range of interfaces, the devices can be easily integrated into the control. The self-adhesive bar code tapes are optimized for industrial application and are extremely durable.

Collision protection

Requirement: When transporting goods by means of an electrical monorail system (EMS), collisions between the individual suspension gears should be avoided. For this purpose, the distance between the suspension gears must be determined.

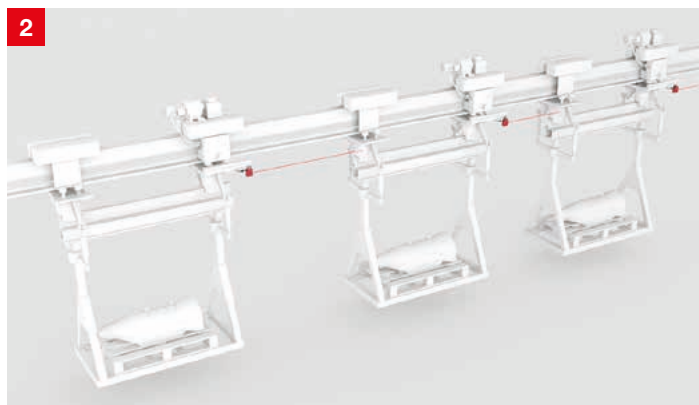

Solution: The ODS 10/HT10 optical distance sensors measure the distance between the suspension gears. The devices measure onto an any object or onto a cooperative reflector. Configuration is performed via the display or IO-Link.

Safeguarding the load pick-up / drop-off area

Requirement: The area where the goods are loaded or unloaded should be secured against access and presence of persons.

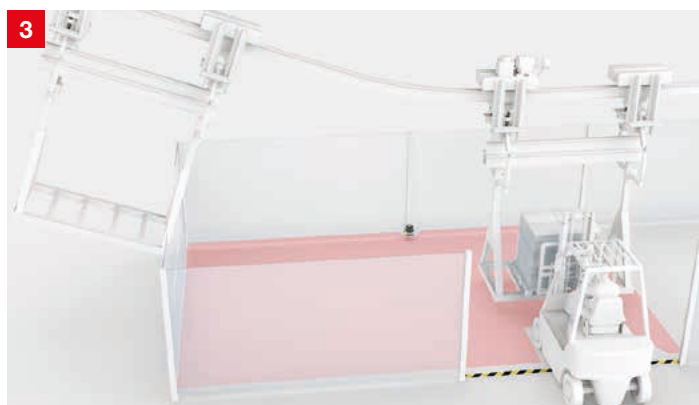

Solution: The RSL 400 safety laser scanners secure even large areas with just one device thanks to their 270° scanning angle and up to 8.25 m operating range. Models with PROFI-safe / PROFINET interface enable easy integration into industrial networks and allow parallel monitoring of up to 4 protective fields.

Code reading on pallets

Requirement: For control of the flow of goods, the goods code on the pallet must be read and transferred to the higher-level system.



Solution: The BCL 500i / 600i series bar code readers read the codes on the pallets. Via the integrated switch, the devices can be connected both to each other and directly to the control via a line structure. Different optics models also allow the devices to be optimally adapted to the reading task.

Sensor solutions for cranes

Goods are warehoused or stored temporarily with industrial crane systems. Automatic positioning of the crane makes the production process much more efficient.

Our sensors ensure process reliability and increase the productivity and availability of your system. In addition, they protect people and materials. The connection between the crane and control is established via the DDLS optical data transceiver sensor. Various sensor systems for position determination enable precise positioning of the crane and control of the gripper. Safety sensors for collision protection avoid possible collisions.



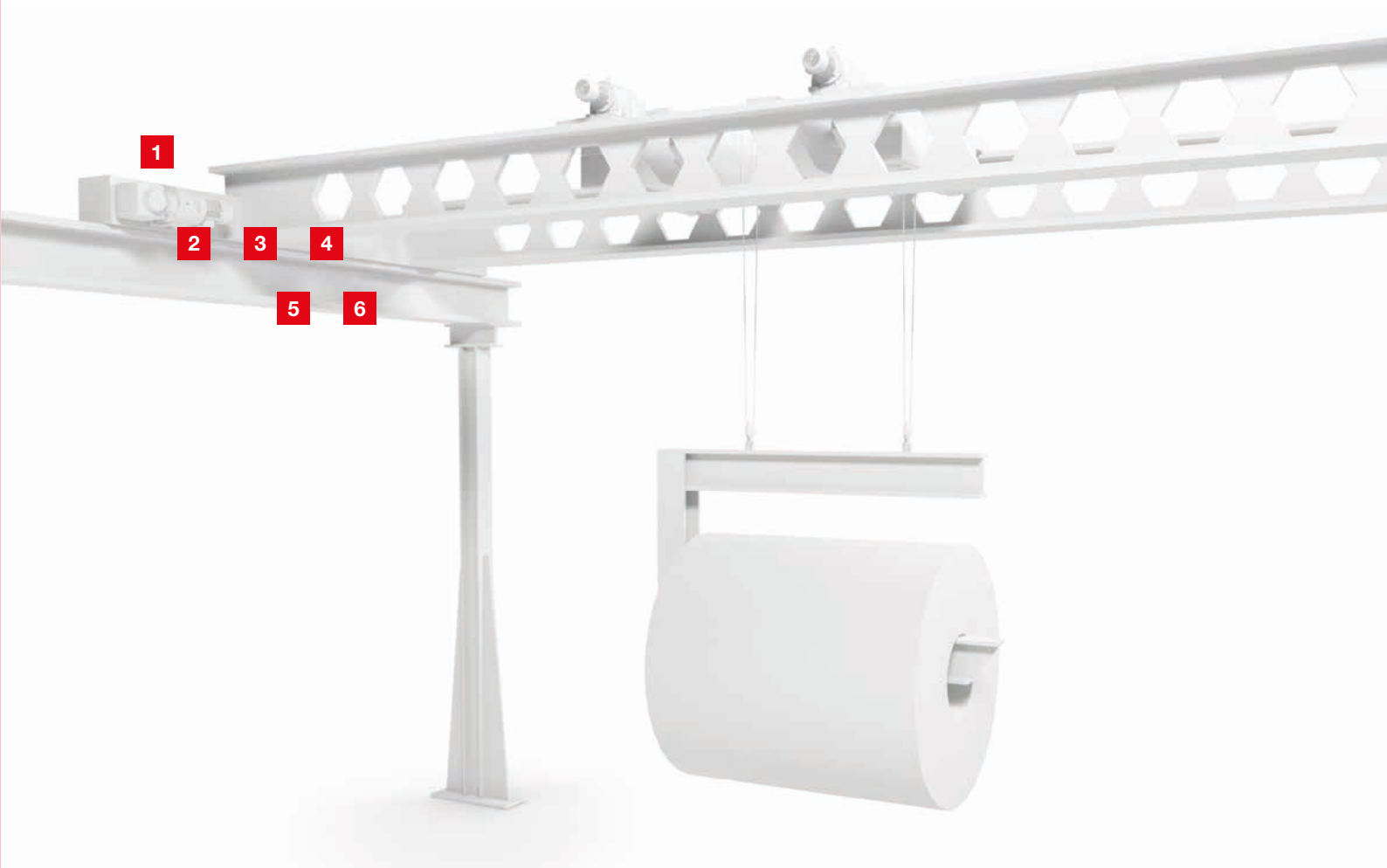

- 1 Optical data transmission up to 100 Mbit/s
- 2 Collision protection / distance monitoring
- 3 Collision protection to protect against damage

- 4 Detection of the final position
- 5 Positioning with bar code positioning system
- 6 Positioning with laser positioning system

Sensor solutions for cranes

Optical data transmission up to 100 Mbit/s

Requirement: From Ethernet-based fieldbuses such as PROFINET, EtherCAT and Ethernet TCP/IP, data should be transmitted wirelessly to the gantry crane or trolley at a transmission rate of up to 100 Mbit/s.

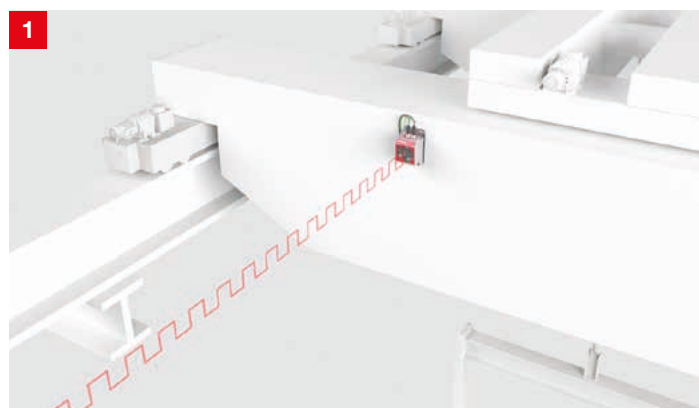

Solution: The DDLS 500 optical data transceiver with industrial Ethernet interfaces transmits data at a rate of up to 100 Mbit/s. The alignment laser and the pre-mounted mounting plate make it particularly easy to align the devices, and the integrated web server ensures fast and location-independent remote diagnosis.

Collision protection / distance monitoring

Requirement: If several cranes are working on the same guide rails, the distance between the cranes must be monitored.

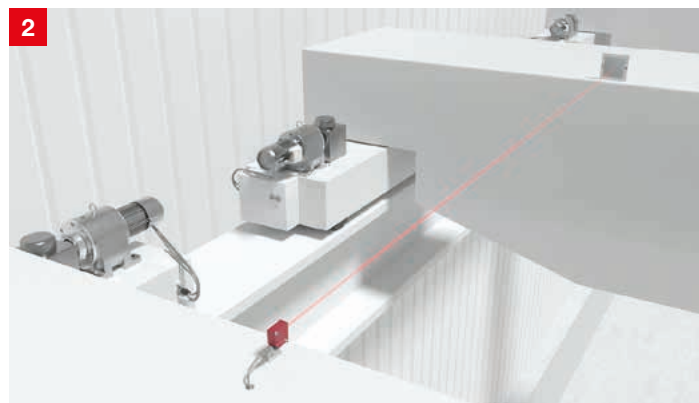

Solution: The ODS 10/HT 10 optical distance sensors measure the distance between the individual cranes. The operating range is up to 8 m when measuring onto any object and up to 25 m when measuring to a cooperative reflector. The information is provided via an analog output or via digital outputs.

Collision protection to protect against damage

Requirement: In order to safely protect the crane from an uncontrolled approach, a setup with safe components must be used to detect the approach and stop the drive.

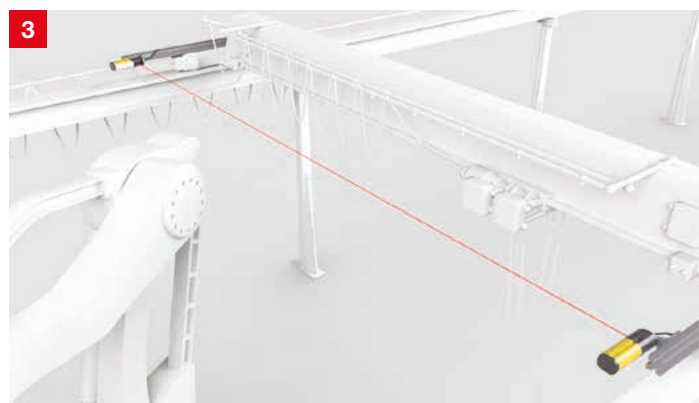

Solution: The compact SLS 46C single light beam safety devices are used together with the MSI-TR evaluation units for periodic testing. Testing is already integrated in the devices of the MLD 500 series. They are used wherever there are no space restrictions or extremely large operating ranges are required.

Detection of the final position

Requirement: The final position of the crane or trolley should be detected.

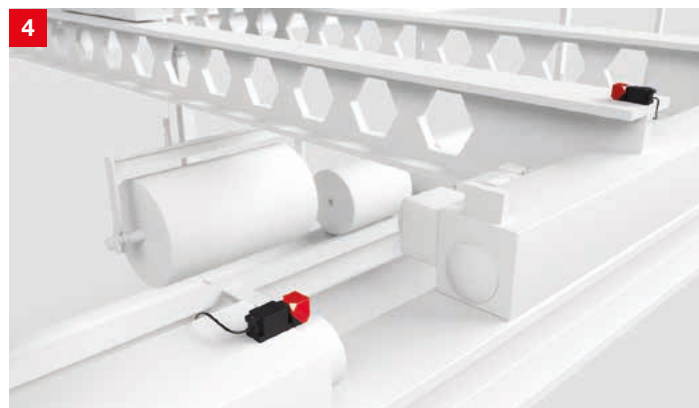

Solution: The IS 244 series inductive sensors detect the final position of the crane or the trolley. Thanks to their sensor field, which can be aligned in five directions, the devices can be mounted flexibly. Versions with M12 connector or comfortable terminal compartment are available for the connection.

Positioning with bar code positioning system

Requirement: The crane or trolley should be positioned according to the position to be approached. Several cranes can be located on one guide rail.

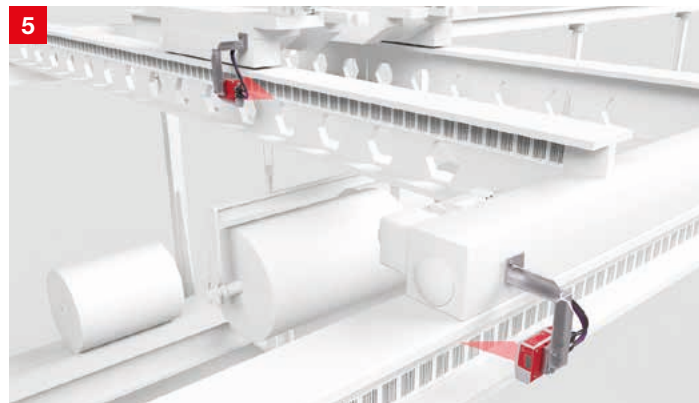

Solution: The BPS 300i compact bar code positioning systems enable exact positioning. Thanks to a wide range of interfaces, the devices can be easily integrated into the control. The self-adhesive bar code tapes are optimized for industrial application and are extremely durable.

Positioning with laser positioning system

Requirement: The crane or trolley should be positioned according to the position to be approached. It is not possible to attach a bar code tape for positioning.

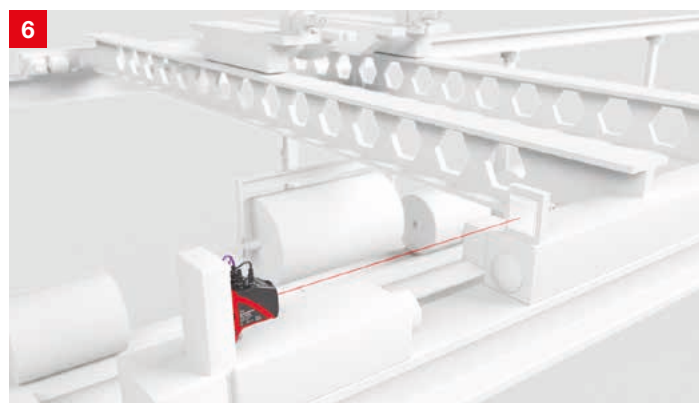

Solution: The AMS 300i laser positioning system quickly determines distances to moving system parts over a distance of up to 300 m with high absolute accuracy. In millisecond intervals, the devices make the measured values available for dynamic control via an extensive selection of industrial Ethernet or fieldbus interfaces.

Sensor solutions for side-tracking shelves

Side-tracking shelves allow storage space to be used economically and efficiently. It must be possible to access the goods in single racks quickly and safely when needed.

Our sensors ensure precise positioning and synchronization of shelves and drives. Single and multiple light beam safety sensors also safeguard the foot space in the shelf rows and access to the shelf aisles.



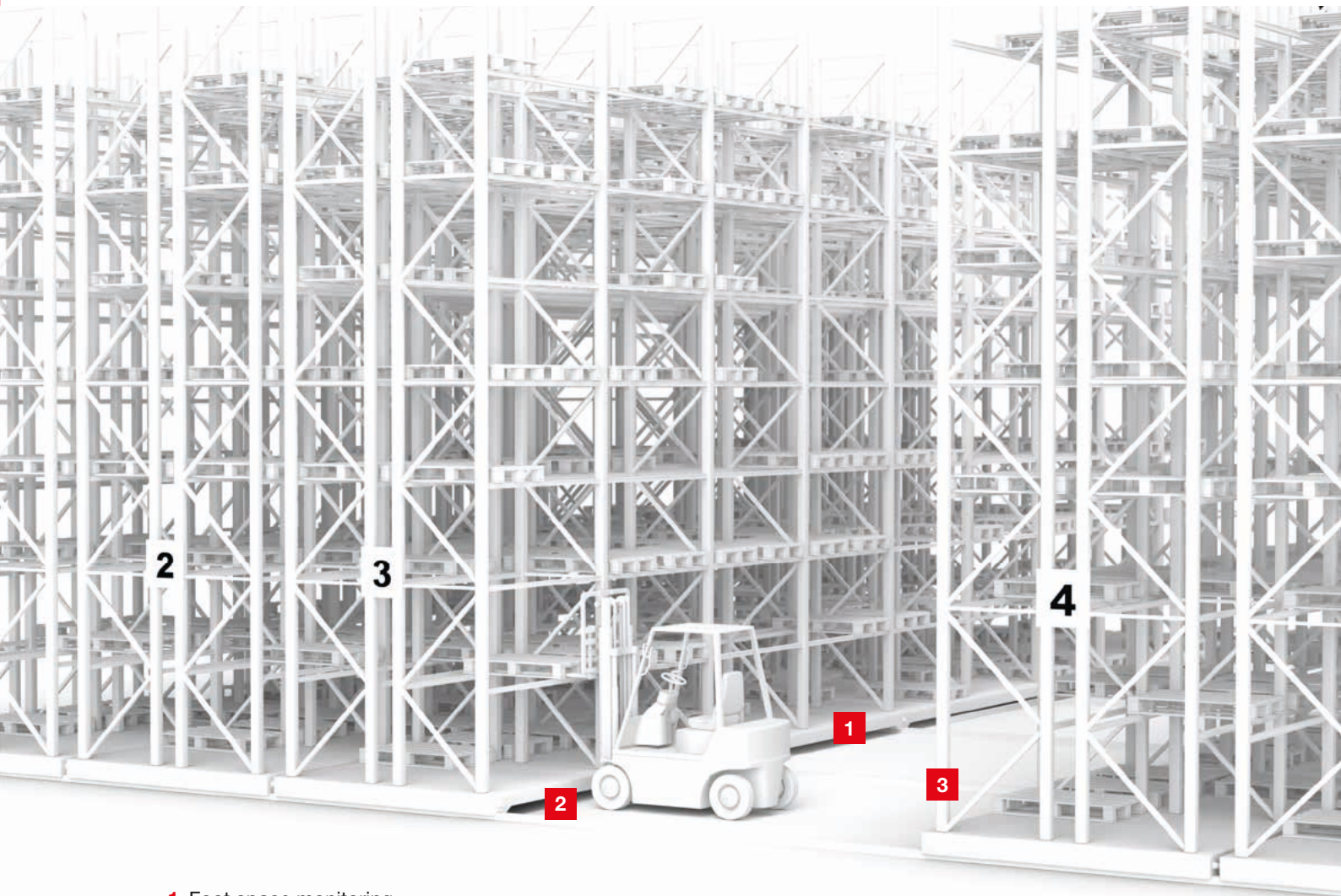

- 1 Foot space monitoring
- 2 Collision protection and distance monitoring
- 3 Access guarding of the aisle

Sensor solutions for side-tracking shelves

Foot space monitoring

Requirement: While the side-tracking shelf is moving, the foot space is to be monitored for the presence of persons. If multiple shelf rows are installed one behind the other, there must be no interference between the sensor signals of the rows.

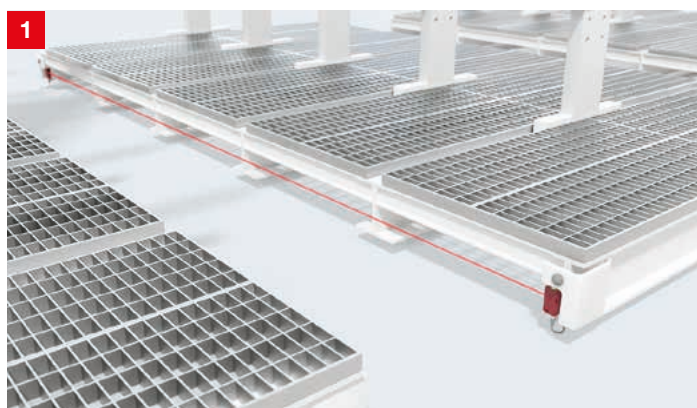

Solution: The SLS 46C single light beam safety devices monitor the foot space over a length of up to 70 m. They are available as a type 4 variant and as a particularly easy-to-align type 2 variant. The use of models with red light and infrared light prevents mutual interference between the shelf rows.

Collision protection and distance monitoring

Requirement: When closing the aisle between two shelves, the shelves should be prevented from moving up. To do this, you need to determine the distance between the shelves. Two distances should be called up via switching outputs.

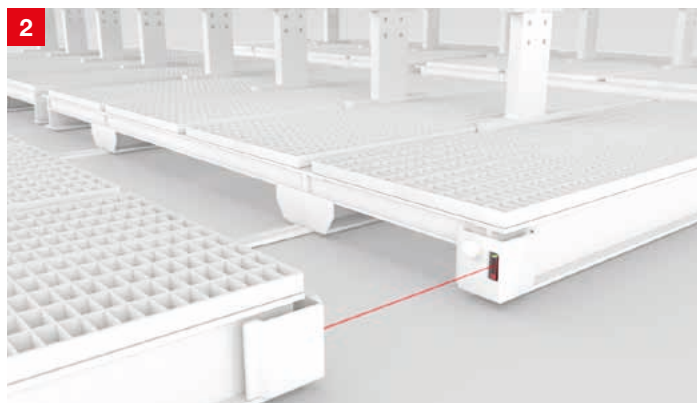

Solution: The HT46C series universal diffuse sensors use red or infrared light and work reliably even with dark and glossy objects. The devices have two switching outputs, each of which can be precisely taught to a distance.

Access guarding of the aisle

Requirement: If a vehicle is in the aisle or the aisle is closed, access to this aisle should be secured.



Solution: The MLD 500 series multiple light beam safety devices are used as access guarding. For operating ranges up to 8 m, particularly cost-effective transceiver systems are available that require an electrical connection on only one side. Alternatively, transmitter / receiver systems offer operating ranges of up to 70 m.

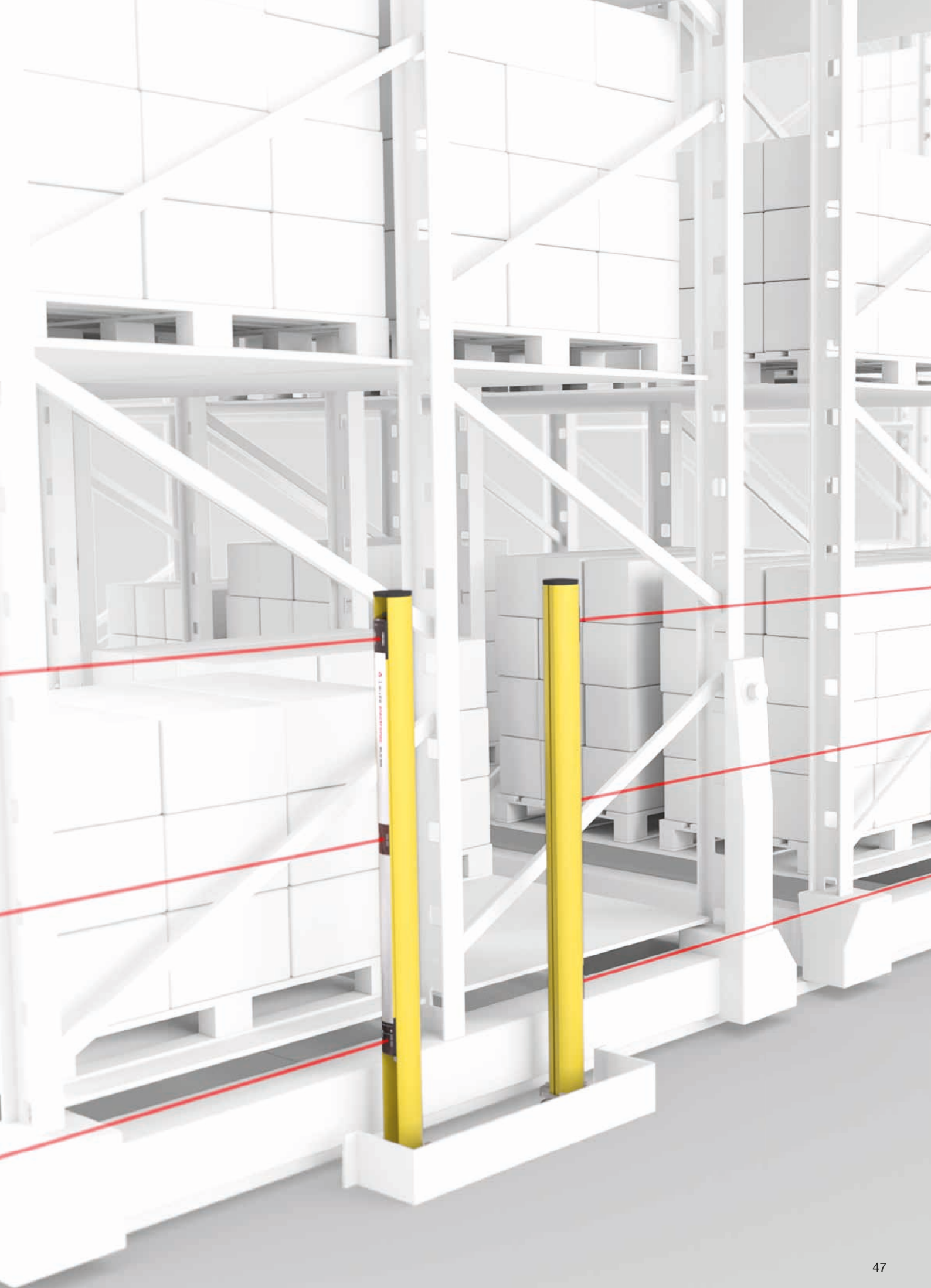

Sensor solutions for order picking

Order picking is the process of collecting goods for customer or production orders. For this purpose, the goods have to be identified reliably and in a user-friendly manner at all times.

Our code readers ensure fast processing of your orders. For both manual and automatic allocation of the goods to a respective order. Reliable and powerful identification increases the profitability of your order picking.



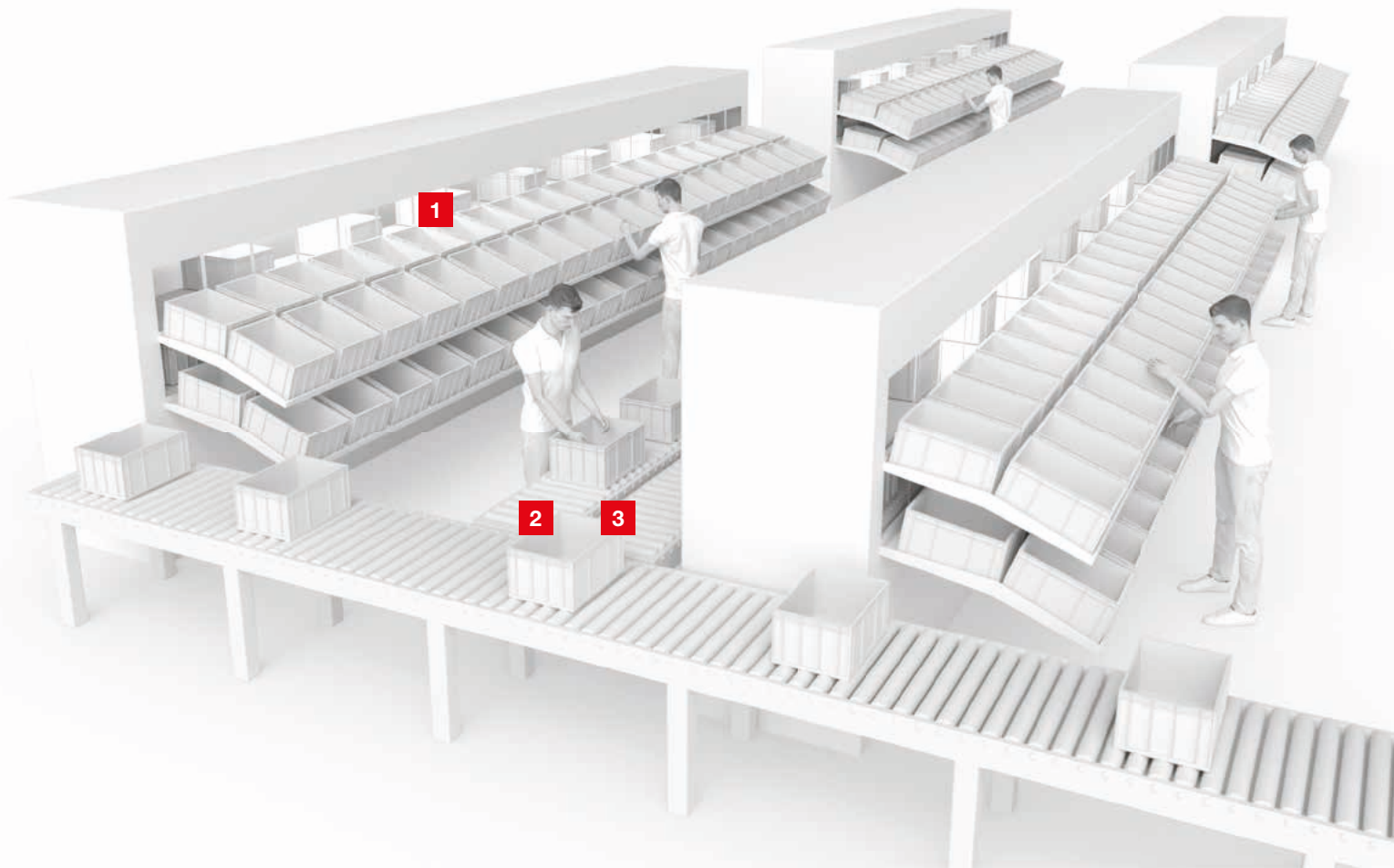

1 Detection of access (pick & place)

2 Mobile code reading

3 Stationary code reading

Sensor solutions for order picking

Detection of access (pick & place)

Requirement: In order to detect from which compartment material has been removed, the intervention in the respective compartment should be monitored for all compartments.

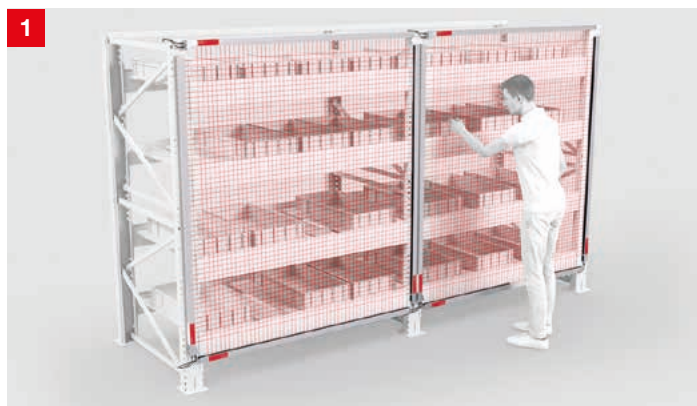

Solution: The CML 700i series measuring light curtains monitor large rack areas with measurement field lengths up to 2,960 mm and a resolution from 5 mm. The integrated interfaces make it easy to integrate the devices into various fieldbuses.

Mobile code reading

Requirement: In order for goods to be assigned to a customer order, the goods code must be read in and transferred to the goods management system.



Solution: The IT 1472Xg series mobile bar code readers read all bar codes commonly used in warehousing and logistics. Depending on the application, versions with cable connection or radio transmission are available.

Stationary code reading

Requirement: If the goods must be held with both hands for code reading, a stationary code reader must be used for reading the goods code.



Solution: The compact, camera-based DCR 200i code reader reads both 1D- and 2D-codes. The device detects the codes by simply presenting them—no external activation is necessary. Standard interfaces such as PROFINET, EtherNet/IP and Ethernet TCP/IP are available for fieldbus integration.

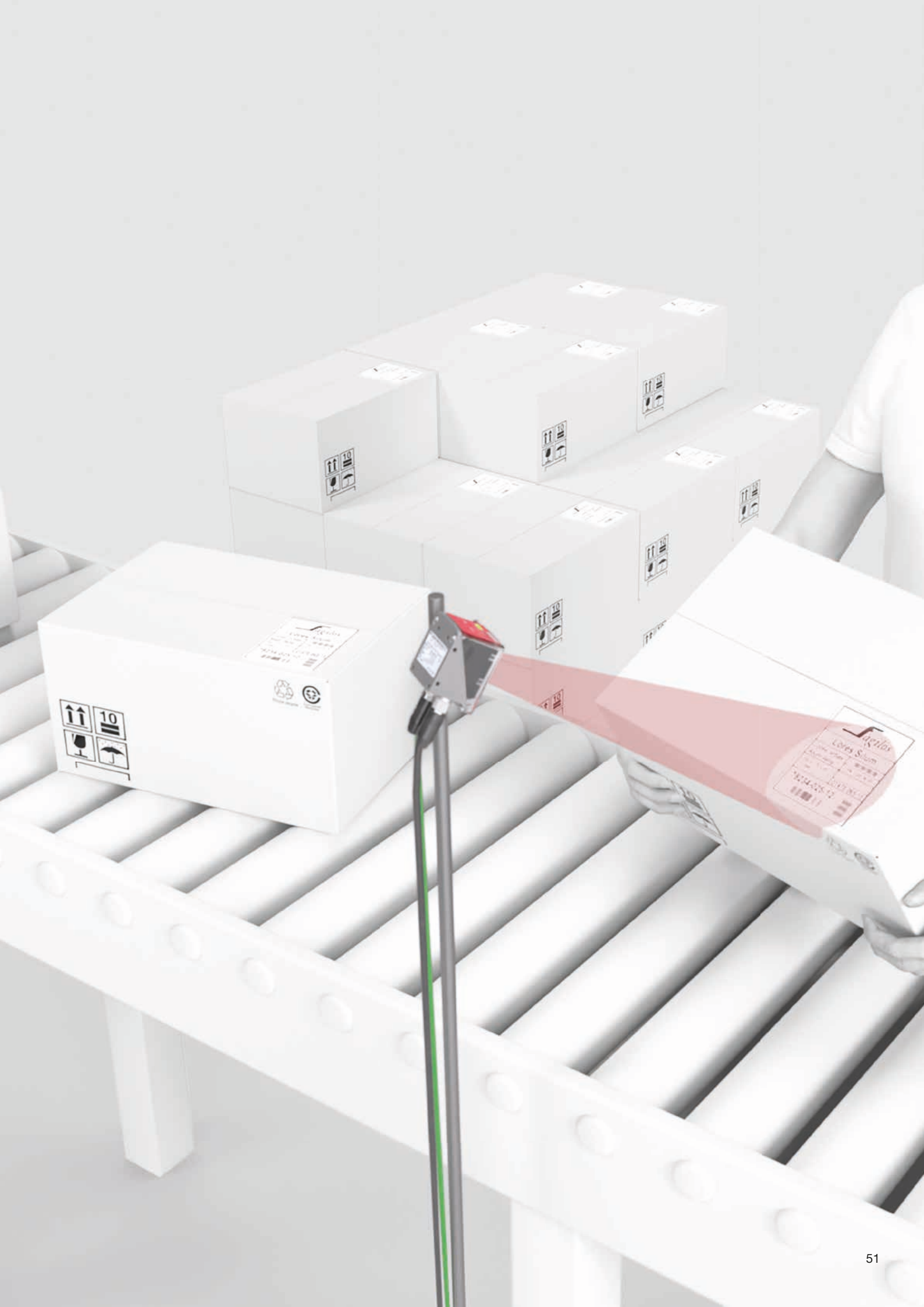

Switching sensors

Photoel. sensors / diffuse sensors, cubic housing



5 series
Standard

15 series
Standard

36 series
Standard

Specifications	Dimensions excl. connector, W × D × H	14 × 32.5 × 20.2 mm	15 × 43 × 30 mm	20.5 × 76.5 × 44 mm
	Operating voltage	10–30V DC	10–30V DC	10–30V DC
	Switching outputs	PNP, NPN	PNP, NPN	PNP, NPN
	Connection type	M8, cable, cable+M8 / M12	M12, cable, cable+M12	M12, cable, cable+M12
	Degree of protection	IP 67	IP 66, IP 67	IP 67
	Certifications	CE cULus	CE cULus	CE CDRH cULus
	Housing	Plastic	Plastic	Plastic
Throughbeam photoelectric sensors	Operating range*	0–15 m	0–30 m	0–100 m
	Light source	Red light, infrared	Red light	Red light
	Switching	Antivalent	Light, dark	Light, dark
	Switching frequency	500 Hz	500 Hz	300 Hz
Retro-reflective photoelectric sensors	Operating range*	0.02–6 m	0–8 / 0–10 m	0.3–21 m
	Light source	Red light	Red light	Red light
	Switching	Antivalent	Light, dark	Light, dark
	Switching frequency	500 Hz	500 Hz	300 Hz
Energetic diffuse sensor	Operating range*	0–1 m		
	Light source	Red light / infrared		
	Switching	Antivalent		
	Switching frequency	500 Hz		
Diffuse sensors with background suppression	Operating range*	0–400 mm	0–1,000 mm	10–2,500 mm
	Light source	Red light	Red light / infrared	Red light / infrared
	Switching	Light, dark	Light, dark	Light, dark
	Switching frequency	1,000 Hz	500 Hz	250 Hz
Additional functions	Transparent media	X		
	Protective sensors category 2/4			
	Warning output			
	Activation input		X	
	Deactivation input	X		
	Active ambient light suppression A ² LS	X	X	
Properties		Simple mounting by means of integrated threaded sleeves Flexible cable outlet to the rear or downward Fast alignment through <i>brightvision</i> Detection of semi-transparent media Teach variants available Detection of empty bottles	Mechanically adjustable operating range Sensitivity adjustment Retro-reflective sensor with large function reserve / for stretch-wrapped containers	Mechanically adjustable operating range Sensitivity adjustment Retro-reflective photoelectric sensor with high function reserve, optionally also for stretch-wrapped objects

**Photoel. sensors / diffuse sensors,
cubic housing**



3C series
Universal, mini

25C series
Universal

46C series
Universal, long range

11 × 32 × 17 mm	15 × 43 × 30 mm	20.5 × 76.3 × 44 mm
10–30V DC	10–30V DC	10–30V DC
Push-pull, PNP, NPN, IO-Link	PNP, NPN, push-pull, IO-Link	PNP, NPN, push-pull
M8, cable, cable+M8 / M12	M8 / M8+snap / M12, cable, cable+M8 / M12	M12, cable, cable+M12
IP 67, IP 69K	IP 67, IP 69K	IP 67, IP 69K
CDRH	CDRH	CDRH
Plastic	Plastic	Plastic
0–10 m	0–30 m	0–150 m
Red light / laser (class 1)	Red light	Red light / infrared
Light, dark, antivalent	Light, dark	Light, dark, antivalent
1,000 / 3,000 Hz	1,500 Hz	100 / 500 Hz
0–7 / 0.02–5.5 / 0–3 m	0–10 / 0–12 / 0–25 m	0.05–30 m
Red light / infrared / laser (class 1)	Red light / laser (class 1 and 2)	Red light
Light, dark, antivalent	Light, dark, antivalent	Light, dark, antivalent
1,000 / 1,500 / 3,000 Hz	1,500 / 2,500 Hz	25 / 150 / 500 Hz
5–600 mm	0–1,200 mm / 0–1,300 mm	5–3,000 mm
Red light / laser (class 1)	Red light / infrared / laser (class 1 and 2)	Red light / infrared / red light laser (class 1 and 2)
Light, dark, antivalent	Light, dark, antivalent	Light, dark, antivalent
1,000 / 3,000 Hz	1,000 Hz / 2,500 Hz	20 / 100 / 200 / 250 / 500 Hz
X	X	
	X (type 2)	X
X	X	X
X	X	X
X	X	X

ECOLAB | Two housing through holes with metal sleeves or threaded sleeves | Sensor with different light-spot geometry and V-configuration | Laser variants | Teach-in | Bottle detection | Contrast sensors | Detection of labels on bottles | Devices with IO-Link communication interface | Teach button with remote function

ECOLAB | M4 metal threaded sleeves | Sensors with small and long light spot | Sensor for bay positioning / for the detection of broken containers | Focused light spot | Foreground suppression | High function reserve | For stretch-wrapped packages | Bottle detection | Laser variants | Teach-in | Dynamic reference diffuse sensor | Long-range sensor | IO-Link interface | Safety-vest sensor

Retro-reflective photoelectric sensors with light-band for objects with openings / irregular contour | Detection of tubular bags on a conveyor belt | Can be used as muting sensor | Roller conveyor sensor | Models for dusty environments | Optimized for parallel operation | Extreme background suppression | Devices with IO-Link interface

Long-range sensors



25 LR series
TOF, long range

110 series
TOF, long range laser

10 series
TOF, long range laser

Specifications	Dimensions excl. connector, W×D×H	15 × 38.9 × 28.7 mm	23 × 50 × 50 mm	25 × 65 × 55 mm
	Operating voltage	10–30V DC	18–30 V DC	18–30 V DC
	Switching outputs	PNP, NPN, push-pull, IO-Link	Push-pull, IO-Link	Push-pull, IO-Link
	Connection type	Cable+M12	Turnable M12 connector	Cable+M12, cable, turnable M12 connector
	Degree of protection	IP 67	IP 67, IP 69K	IP 67
	Certifications	CDRH	CDRH	CDRH
Housing	Plastic	Plastic	Plastic	
Diffuse sensors with background suppression	Operating range*	50–3,000 mm	100–5,000 mm (WH)/ 3,000 mm (BK)	50–8,000 mm/25,000 mm
	Light source	Infrared TOF (light propagation time measurement)	Red light laser (class 1)	Red light laser (class 1)
	Switching	Light, dark	Light	Light
	Switching frequency	30 / 40 Hz	250 Hz	40 Hz
Additional functions	Transparent media			
	Protective sensors category 2/4			
	Warning output	X		X
	Activation input	X	X	X
	Active ambient light suppression A ² LS			X
Properties		Detection of objects with low diffuse reflection > 4% 2 teachable switching points (TOF) Line teach and deactivation All devices with IO-Link interface for configuration (including adaptation to the application) and process data transfer Very good fading Operating range adjustment via IO-Link	All devices with IO-Link interface Turnable M12 connector 2 switching points Small black-white error High repeatability Adjustment via teach buttons Propagation time of the radiated light (TOF)	Turnable M12 connector All devices with IO-Link interface Light/dark switching via teach button Window function Adaptation to the application by means of configurable filters and gain values Propagation time of the radiated light (TOF)

Inductive switches



IS 208, 212, 218, 230
Standard, cylindrical



IS 208, 212, 218, 230
All stainless steel



IS 255, 288
Miniature sensors,
cubic housing



IS 240, 244/ISS 244
Standard, cubic

	IS 208, 212, 218, 230 Standard, cylindrical	IS 208, 212, 218, 230 All stainless steel	IS 255, 288 Miniature sensors, cubic housing	IS 240, 244/ISS 244 Standard, cubic	
Specifications	Dimensions incl. connector, W x D x H	M8: 22–45 mm M12: 35–60 mm M18: 35–64 mm M30: 40.6–73.5 mm	M8: 45–60 mm M12: 50–60 mm M18: 51–63.5 mm M30: 50–63.5 mm	5 x 5 x 25 mm 8 x 8 x 40 mm 8 x 8 x 59 mm	12 x 40 x 26 mm 40 x 40 x 67 mm 40 x 40 x 118 mm
	Type of installation	Embedded / non-embedded	Embedded / non-embedded	Embedded	Embedded / non-embedded
	Operating voltage	10–30V DC	10–30V DC	10–30V DC	10–30V DC
	Operating range	2–40 mm	2–40 mm	1.5–3 mm	4–40 mm
	Switching outputs	PNP, NPN	PNP, NPN	PNP, NPN	PNP, NPN
	Switching principle	NO, NC, NO + NC (antivalent)	NO, NC	NO, NC	NO + NC (antivalent)
	Switching frequency	Up to 5,000 Hz	Up to 600 Hz	Up to 5,000 Hz	Up to 1,400 Hz
	Connection type	M12, cable + M12, cable	M8, M12, cable	M8, cable + M8, cable	M8, M12, terminal, cable
	Degree of protection	IP 67	IP 67, IP 68, IP 69 K	IP 67	IP 67, IP 68, IP 69 K
	Certifications	CE cULus	CE cULus	CE cULus	CE cULus
Housing	Metal	All stainless steel (V2A & V4A)	Metal	Plastic	
Properties	Different versions available: Short housing design Increased range AC/DC device versions Antivalent switching output	Full stainless steel housing from a single piece (V2A & V4A) Resistant against vibration and pressure shocks Mechanically resistant against impacts on the active surface Also available as a model with 316L stainless steel (ECOLAB) suitable for use in hygienic applications Correction factor 1 (material-independent detection)	Cubic miniature housing Versions with increased operating range	Bright status display Complementary switching outputs (NO+NC) Increased ranges M12 plug, turnable 270° and thus suitable even for angled connection cables 360° visibility through 4-way LED indicator on the sensor head	

Measuring Sensors

Switching and measuring light curtains / volume measurement system



CSL 710
Switching

CML 700i
Measuring

CMS 700i
Measuring

Specifications	Function	Throughbeam principle	Size / contour detection, optical	Size / contour detection, optical
	Dimensions excl. connector, W x D x H	29 x 35 x 168 ... 2,968 mm	29 x 35 x 168 ... 2,968 mm	Dependent on the system configuration
	Operating voltage	18–30 V DC	18–30 V DC	230 V AC
	Outputs	4 I/Os (configurable) + IO-Link	Analog, CANopen, IO-Link, PROFIBUS, PROFINET, RS 485 (MODBUS)	4 I/Os, Ethernet TCP/IP, PROFINET
	Connection type	M12	M12	M12 and grounding bolts
	Degree of protection	IP 65	IP 65	IP 54 switch cabinet / IP 65 light curtain
	Certifications			
	Maximum operating range*	3.5 ... 7 m	4.5 ... 9.5 m	3.5 ... 7 m
	Light source / Measurement principle	Infrared	Infrared	Infrared
	Cycle time / measurement time	30 μs per beam	10–30 μs per beam + 0,4 ms	Dependent on conveyor speed and object size
	Measurement field length / scanning angle	160–2,960 mm	160–2,960 mm	5 mm resolution: 50 x 50 x 5 mm ³ – ** 2,400 x 1,200 x 1,200 mm ³ 10 mm resolution: 50 x 50 x 5 mm ³ – 2,400 x 2,400 x 2,400 mm ³ (L x W x H)
	Resolution	5, 10, 20, 40 mm	5, 10, 20, 40 mm	5, 10 mm
	Number of beams	Max. 592	Max. 592	
Operation	Control buttons on foil display, 5 languages, configuration software	Control buttons on foil display, 5 languages, configuration software	webConfig	
Properties		8 switching ranges Simple area splitting 4 switching outputs + 1 IO-Link Robust metal housing Extremely fast cycle time Display for diagnosis and alignment Suitable for low-temperature applications down to –30 °C	Cycle time CML 730: 10 μs x number of beams + 0.4 ms Cycle time CML 720: 30 μs x number of beams + 0.4 ms Detection of transparent media Display for diagnosis and alignment Standard profile for simple mounting Robust metal housing Suitable for low-temperature applications down to –30 °C	Contour measurement system for passing objects Output of the smallest enclosing cuboid of the object Output of object protrusions and bulges Output of the object position and orientation angle on the conveyor Collection and looping through of external data from, e.g., scales, bar code readers Easy commissioning by the customer Total system can be ordered with one part number

* Guaranteed operating range, depending on the resolution

** Minimum object height 5 mm only for version with rotary encoder for length measurement; minimum object height for version with light curtain for length measurement is 50 mm

Distance sensors



ODS 10
Optical distance sensors

ODS 110
Optical distance sensors

	ODS 10 Optical distance sensors	ODS 110 Optical distance sensors	
Specifications	Function	Distance measurement, optical	Distance measurement, optical
	Dimensions excl. connector, W x D x H	25 x 65 x 55 mm	23 x 50 x 50 mm
	Operating voltage	18–30 V DC	18–30 V DC
	Outputs	4–20 mA 1–10 V, 0–10 V Push-pull IO-Link	4–20 mA 1–10 V 1x push-pull IO-Link
	Connection type	M12	M12
	Degree of protection	IP 67	IP 67
	Certifications	CE CDRH cULUS	CE cULUS
	Measurement range	50–3,500 mm 50–8,000 mm (90 % diffuse reflection) 100–25,000 mm on reflective tape	100–3,000 mm 100–5,000 mm (90 % diffuse reflection)
	Measurement principle	Optical / laser (class 1)	Optical / laser (class 1)
	Measurement time	3,4–1,020 ms (adjustable)	4–20 ms
	Measurement field width / Scanning angle		
	Ultrasonic frequency		
	Resolution	1 mm	1 mm
	Mouth width		
Mouth depth			
Number of inspection tasks			
Operation	Control buttons on foil display or Sensor Studio	Teach-in or Sensor Studio	
Properties	Display for measured value display and configuration Turnable M12 connector All devices with IO-Link interface Propagation time measurement (TOF)	All devices with IO-Link interface Turnable M12 connector Adjustment via teach button Propagation time measurement (TOF)	

Optical laser distance sensors



AMS 300i

Bar code positioning systems



BPS 8



BPS 300i



FBPS 600i

Specifications	Function	Distance measurement, optical	Position detection, optical	Position detection, optical	Safe position detection, optical
	Operating range	40 / 120 / 200 / 300 m	10,000 m	10,000 m	10,000 m
Reading distance			60 ... 140 mm	50 ... 170 mm	50 ... 170 mm
Interfaces	Integrated: PROFIBUS and SSI PROFINET PROFINET and SSI DeviceNet EtherCAT EtherNet/IP CANopen Ethernet TCP/IP, UDP Interbus-S RS 232, RS 422, RS 485 SSI	Integrated: RS 232	Integrated: PROFINET EtherCAT PROFIBUS SSI RS 422 RS 232 RS 485	Integrated: 2 x SSI	
Connectivity	Via the interfaces mentioned above	With MA 200i connection unit PROFINET IO/RT, PROFIBUS, Ethernet TCP/IP, UDP, IP, EtherCAT, DeviceNet, CANopen			
Position calculation through	Reflector	Bar code tape	Bar code tape	Bar code tape	Bar code tape
Measurement value output	1.7 ms	3.3 ms	1 ms	1 ms	
Reproducibility	±0.9 / 1.5 / 2.1 / 3 mm (3 sigma)	±1 mm (3 sigma)	±0.15 mm (3 sigma)	±0.45 mm (3 sigma)	
Accuracy	±2 / 2 / 3 / 5 mm				
Degree of protection	IP 65	IP 67	IP 65	IP 65	
Light source	Red light laser (class 2)	Red light laser (class 2)	Red light laser (class 1)	Red light laser (class 1)	
Supply voltage	18–30 V DC	5V DC (24 V DC via MA 8-01)	18–30 V DC	24 V DC ±25 %	
Operating temperature	-5 ... +50 °C (-30 ... +50 °C with heating)	0 ... +40 °C	-5 ... +50 °C (-35 ... +50 °C with heating)	-5 ... +60 °C (-35 ... +60 °C with heating)	
Options	Speed measurement and monitoring	Customer-specific configuration facility	Speed measurement and monitoring	Safety parameters: PL e, category 4 in accordance with EN ISO 13849-1 SIL 3 in accordance with IEC 61508 Error reaction time: 10 ms ... 400 ms (adjustable)	
Certifications	CE CDRH cUL US	CE CDRH cUL US	CE CDRH cUL US	CE CDRH cUL US TUV	
Properties	Absolute measurement system with very high accuracy Simultaneous use of the PROFIBUS and SSI or PROFINET and SSI interface Easy programming via extensive configuration file Optionally with heating Multiple language menu-driven display Heatable reflectors available as accessories	Positioning also in curves and gradients as well as at track switches Compact metal housing Turnable M12 connector Large selection of different protocols via external MA 200i connection units	Positioning also in curves and gradients as well as at track switches Metal housing Connection via terminal, M12 or cable Clamp bracket for fast and position-neutral mounting Extensive diagnostic options Comfortable programming via GSDML / GSD or ESI files Optional: heating, display	Positioning also in curves and gradients as well as at track switches Connection at side or underneath Metal housing Clamp bracket with quick clamp device for fast and position-neutral mounting Optional: heating or display	

Optical guidance



OGS 600

Specifications	Detection width	115 ... 265 mm
	Working range	10 ... 70 mm
	Light source	10 ms
	Cycle time	1 × PNP 1 × programmable input/output (RS 485 and RS 422)
	Switching inputs / outputs	CANopen, RS 422, RS 485
	Housing	Diecast aluminum
	Degree of protection	IP 65
	Operating voltage	18–30 V DC
	Operating temperature	–15 ... +50 °C
	Certifications	c_{UL} US
Properties	Solid-state guidance – highest reliability due to complete absence of moving components Insensitive to unevenness thanks to passive optics with large detection range Detects up to 6 parallel traces Adjustable process data type	

3D sensors – Light section sensors



**LPS 36, 36 HI
LES 36, 36 HI
LRS 36**

Specifications	Function	Distance measurement, light section, optical
	Dimensions excl. connector, W × D × H	56 × 74 × 160 mm
	Operating voltage	18–30 V DC
	Outputs	4–20 mA 1–10 V Ethernet 4 × push-pull PROFIBUS
	Connection type	M12
	Degree of protection	IP 67
	Certifications	CE CDRH c_{UL} US
	Operating range*	200–800 / 200–600 mm
	Measurement principle	Optical / laser (class 2M)
	Measurement time	10 ms
	Measurement field width / Scanning angle	Max. 600 mm / max. 140 mm
	Resolution	0.1–6 mm
	Mouth width	
	Mouth depth	
	Number of inspection tasks	16
	Operation	Configuration software Display
Properties	LPS 36: light section sensor for 2D/3D object measurement LPS 36 HI: highly precise with a resolution of 0.1 mm LES 36: light section sensor for width / height and position measurement LRS 36: light section sensor for object detection in up to 16 detection fields Alignment aid with OLED display; inputs: activation, cascading, trigger Optional: encoder port	

Sensors for compartment fine positioning

Industrial IP cameras



IPS 200i
Sensors for positioning

IPS 400i
Sensors for positioning

LCAM 308
Monitoring camera

Specifications	Task	Compartment fine positioning, single compartment depth	Compartment fine positioning, double compartment depth	Live-image transfer, image transfer recording
	Sensor / cameras	CMOS (Global Shutter)	CMOS (Global Shutter)	Color CMOS
	Resolution (pixel)	1,280 × 960	1,280 × 960	1,280 × 720
	Focal point	Reading distance 100... 600 mm Marker dependent	Reading distance 250–2,400 mm Marker-dependent	
	Working range			500 mm ... ∞
	Interface	Integrated: Ethernet TCP/IP, UDP PROFINET IO/RT, EtherNet/IP	Integrated: Ethernet TCP/IP, UDP PROFINET IO/RT, EtherNet/IP	Ethernet
	Digital inputs/outputs	3x IN; 5x OUT	3x IN; 5x OUT	1x IN
	Transmission rate			10/100 Mbit/s
	Optional	Cables, mounting devices, reflectors, heating model to –30°C	Cables, mounting devices, reflectors, heating model to –30°C, external illumination	Cables, mounting devices, network switch
	Number of test routines	8	8	
	Configuration/Operating system	Web-based configuration tool (webConfig tool) XML commands; 2x operational controls	Web-based configuration tool (webConfig tool) XML commands; 2x operational controls	webConfig
	Options	Configuration on the device via configuration codes	Configuration on the device via configuration codes	Trigger input, integrated memory, heating
Dimensions, W × H × D	43 × 61 × 44 mm	43 × 61 × 44 mm	85 × 114 × 35 mm	
Certifications	CE cUL US	CE cUL US	CE UK CA	
Properties	Time savings through fast commissioning via web-based configuration tool or printed configuration codes Innovative alignment system via feedback LEDs simplifies alignment One device for the entire region of interest from 100–600 mm Quality score enables the early detection of a deterioration in reading performance Can be used flexibly thanks to high-performance, infrared LED illumination that is independent of ambient light Model with integrated heating for use to –30°C		Time savings through fast commissioning via web-based configuration tool or printed configuration codes Innovative alignment system via feedback LEDs simplifies alignment Quality score enables the early detection of a deterioration in reading performance One device for double-depth working range from 250–2,400 mm Can be used flexibly thanks to high-performance, infrared LED illumination that is independent of ambient light Model with integrated heating for use to –30°C	
Very well suited for industrial use through glass window and metal housing Degree of protection IP 65 Megapixel color camera chip for live-image transfer in MJPEG format Operating temperature –30...50 °C				

Safety

Safety laser scanners



RSL 410, RSL 420, RSL 425

RSL 430, RSL 440, RSL 445

RSL 420P, RSL 450P, RSL 455P

	RSL 410, RSL 420, RSL 425	RSL 430, RSL 440, RSL 445	RSL 420P, RSL 450P, RSL 455P	
General	Protective field range	3,0 / 4,5 / 6,25 / 8,25 m	3,0 / 4,5 / 6,25 / 8,25 m	3,0 / 4,5 / 6,25 / 8,25 m
	Scanning angle	270°	270°	270°
	Angular resolution	0.1°	0.1°	0.1°
	Warning field range (at 10% diffuse reflection)	20 m	20 m	20 m
	Resolution, selectable	30 / 40 / 50 / 60 / 70 / 150 mm	30 / 40 / 50 / 60 / 70 / 150 mm	30 / 40 / 50 / 60 / 70 / 150 mm
	Response time	≥ 80 ms	≥ 80 ms	≥ 120 ms
	Safety	Type 2, SIL 3, PL d	Type 2, SIL 3, PL d	Type 2, SIL 3, PL d
	Dimensions, incl. connection unit (W × H × D)	140 × 149 × 140 mm	140 × 149 × 140 mm	140 × 169 × 140 mm
	Temperature range	0 ... +50 °C	0 ... +50 °C	0 ... +50 °C
Certifications	CE CDRH cUL US TÜV TÜV	CE CDRH cUL US TÜV TÜV	CE CDRH cUL US TÜV	
Functions	Safety-related switching outputs	1	2	RSL 420P: PROFIsafe, 1 protective field RSL 450P, 455P: PROFIsafe, 4 simultaneous protective fields
	Number of field pairs (1 protective field + 1 warning field)	RSL 410: 1 RSL 420: 10	RSL 430: 10+10 RSL 440, 445: 100	RSL 420P: 10 RSL 450P, 455P: 100
	Number of 4-field sets (1 protective field + 3 warning fields)	RSL 410: 1 RSL 420: 10	10	RSL 420P: 10
	Number of 4-field sets (2 protective fields + 2 warning fields)	–	50	RSL 450P, 455P: 50 (Warning fields can be evaluated as protective fields)
	Number of independent sensor configurations	1	RSL 430: 2 RSL 440, 445: 10	RSL 420P: 1 RSL 450P, 455P: 10
	Plain-text display, integrated electronic spirit level	X	X	X
	Configurable signal outputs	RSL 410: 3 RSL 420: 4	9	All status information can be called up
	UDP data output optimized for AGV navigation, configurable, 50 m operating range	RSL 425 Distance and signal strength, angular resolution 0.1°	RSL 445 Distance and signal strength, angular resolution 0.1°	RSL 455P Distance and signal strength, angular resolution 0.1°
Interfaces / connection	Connection unit (removable, with integrated configuration memory)	RSL 410: M12 connector, RSL 420, 425: cable or connector, 16-pin	Cable or connector, 29-pin	3x M12 connector for 2-port switch and voltage supply or 4x M12 connector with additional voltage output AIDA variant with push-pull connectors, communication via copper or fiber-optic cable
	Interfaces for configuration and diagnosis	Ethernet TCP/IP, Bluetooth RSL 420, 425: USB	Ethernet TCP/IP, USB, Bluetooth	Ethernet TCP/IP, USB, Bluetooth
	PROFINET	–	–	Conformance class C Network load class III PROFINET device acc. to Specification V2.3.4 GSDML acc. to Specification V2.3.2
	Further features	Technology for robust operation Contactor monitoring (EDM), start/restart interlock (RES) Vertical access guarding with reference boundary monitoring Parking function (protective field switchover, RSL 420 and RSL 425)	Technology for robust operation Contactor monitoring (EDM), start/restart interlock (RES) Vertical access guarding with reference boundary monitoring Parking function (protective field switch-off)	Technology for robust operation Start/restart interlock (RES) Vertical access guarding with reference boundary monitoring Parking function (protective field switch-off)

Safety light curtains



ELC 100



MLC 310, MLC 320
MLC 510, MLC 520



MLC 530



MLC 530-SPG

	ELC 100	MLC 310, MLC 320 MLC 510, MLC 520	MLC 530	MLC 530-SPG	
General	Type in accordance with EN IEC 61496	Type 4	MLC 300: type 2 MLC 500: type 4	Type 4	
	SIL in accordance with IEC 61508 and EN IEC 62061 (SILCL)	SIL 3	MLC 300: SIL 1 MLC 500: SIL 3	SIL 3	
	Performance Level (PL) in accordance with EN ISO 13849-1	PL e	MLC 300: PL c MLC 500: PL e	PL e	
	Resolution	17 / 30 mm	14 / 20 / 30 / 40 / 90 mm	14 / 20 / 30 / 40 / 90 mm	30 / 40 / 90 mm
	Operating range	3 / 6 m	6 / 15 / 10 / 20 / 20 m	6 / 15 / 10 / 20 / 20 m	10 / 20 / 20 m
	Protective field height	0 ... 1,500 mm	150 ... 3,000 mm	150 ... 3,000 mm	150 ... 3,000 mm
	Response time	4.5 – 21 ms	MLC 300: 3 – 51 ms MLC 500: 3 – 64 ms	3 – 64 ms	3 – 64 ms
	Profile cross section	34.7 mm × 39.3 mm	29 × 35 mm	29 × 35 mm	29 × 35 mm
	Temperature range	0 ... +55 °C	MLC 300: 0 ... +55 °C MLC 500: –30 ... +55 °C	–30 ... +55 °C	–30 ... +55 °C
	Degree of protection	IP 65	IP 65	IP 65	IP 65
	Safety-related switching outputs (OSSDs)	2 PNP transistor outputs	2 PNP transistor outputs	2 PNP transistor outputs	2 PNP transistor outputs
	Connection type	150 mm cable with M12 connector	M12 connector	M12 connector	M12 connector
Certifications					
Functions	Range reduction on the transmitter		X	X	
	Switchable transmission channels		X	X	
	LED indicator	X (additional alignment indicator)	X	X	X
	7-segment display		MLC 320, 520	X	X
	Configuration by means of wiring		X	X	X
	Automatic start / restart	X	X	X	
	Start / restart interlock (RES)		MLC 320, 520	X	X
	Contactormonitoring (EDM)		MLC 320, 520		
	Beam blanking, fixed or movable			X	X
	Muting function, integrated			X (2-sensor timing controlled)	X (Smart Process Gating)
Versions for special applications	Extremely slim design				
	Cascadable (triple)		MLC 520		
	AIDA version		MLC 510		
	AS-i Safety interface		MLC 510		
	Ex marking acc. to EN 60079		MLC 520 (group II, cat 3D and 3G)		
	Degrees of protection IP 67 / IP 69K, mounted in protective tube		MLC 510		
	Extra shock / vibration resistant	X (standard for all devices)	MLC 500	X	

Multiple light beam safety devices



**MLD 310, MLD 320
MLD 510, MLD 520**



**MLD 330, MLD 335
MLD 530, MLD 535**

Single light beam safety devices



**MLD 510, MLD 520,
MLD 530**



**SLS 46C type 4
SLS 46C type 2**

	MLD 310, MLD 320 MLD 510, MLD 520	MLD 330, MLD 335 MLD 530, MLD 535	MLD 510, MLD 520, MLD 530	SLS 46C type 4 SLS 46C type 2	
General	Type in accordance with EN IEC 61496	MLD 300: type 2 MLD 500: type 4	MLD 300: type 2 MLD 500: type 4	Type 4 (self-monitoring)	
	SIL in accordance with IEC 61508 and EN IEC 62061 (SILCL)	MLD 300: SIL 1 MLD 500: SIL 3	MLD 300: SIL 1 MLD 500: SIL 3	SIL 3	SIL 3 (SLS 46C type 4 with MSI-TRM safety relay) SIL 1 (SLS 46C type 2 in combination with safety monitoring device)
	Performance Level (PL) in accordance with EN ISO 13849-1	MLD 300: PL c MLD 500: PL e	MLD 300: PL c MLD 500: PL e	PL e	PL e (SLS 46C type 4 with MSI-TRM safety relay) PL c (SLS 46C type 2 in combination with safety monitoring device)
	Number of beams / beam distance	2 / 500 mm 3 / 400 mm 4 / 300 mm	2 / 500 mm 3 / 400 mm 4 / 300 mm	1	1
	Operating range	0.5 ... 50 m or 20 ... 70 m (transmitter-receiver systems) 0.5 ... 6/8 m (transceiver systems)	0.5 ... 50 m or 20 ... 70 m (transmitter-receiver systems) 0.5 ... 6/8 m (transceiver systems)	0.5 ... 70 m 20 ... 100 m	0.25 ... 40 m 5 ... 70 m
	Dimensions	Profile cross section 52 x 65 mm	Profile cross section 52 x 65 mm	52 x 65 x 193 mm	20.5 x 77 x 44 mm
	Temperature range	-30 ... +55 °C	-30 ... +55 °C	-30 ... +55 °C	-30 ... +60 °C
	Safety-related switching outputs	2 PNP transistor outputs (OSSDs)	2 PNP transistor outputs (OSSDs)	2 PNP transistor outputs (OSSDs)	2 push-pull transistor outputs
	Connection type	M12 connector	M12 connector	M12 connector	2 m cable, M12 connector
	Certifications				
Functions	LED indicator	X	X	X	
	7-segment display	MLD 320, 520	X	MLD 520, 530	
	Start / restart interlock (RES)	MLD 320, 520	X	MLD 520, 530	
	Contactormonitoring (EDM)	MLD 320, 520	X	MLD 520, 530	
	Configuration by means of wiring	MLD 320, 520	X	MLD 520, 530	
	Laser alignment aid (optional for transmitter/receiver systems)	X	X	X	
	2-sensor muting (timing and sequence controlled)		MLD 330, 530 MLD 335, 535	MLD 530	
	4-sensor muting (timing controlled)		MLD 335, 535		
	Muting-timeout extension to up to 100 hours		MLD 330, 530 MLD 335, 535	MLD 530	
	Shortened muting timeout (10 seconds)		MLD 531		
	Integrated status indicator (optional)	X	X		
	AS-i Safety interface	MLD 510		MLD 510	

Identification

Stationary bar code readers



	BCL 200i	BCL 300i	BCL 500i	BCL 600i	
Specifications	Reading distance (dependent on version)	40–255 mm	20–700 mm	200–2,400 mm	300–1,500 mm
	Smallest resolution	0.2 mm	0.127 mm	0.2 mm	0.25 mm
	Scanning rate	1,000 scans/s	1,000 scans/s	1,000 scans/s	800–1,000 scans/s
	Optics models	M	N, M, F, L, J	N, M, F, L	M, F
	Reading method	Single line scanner Raster scanner Deflecting mirror Code reconstruction technology	Single line scanner Raster scanner Deflecting mirror Oscillating mirror Code reconstruction technology	Single line scanner Oscillating mirror Code reconstruction technology	Single line scanner Oscillating mirror Code reconstruction technology
	Inputs/outputs	1 / 1	1 / 1	2 / 2	2 / 2
	Interfaces	Integrated: PROFINET IO/RT Ethernet TCP/IP EtherNet/IP	Integrated: RS 232 / 485 / 422 multiNet PROFIBUS PROFINET IO/RT Ethernet TCP/IP, UDP Ethernet IP EtherCAT	Integrated: RS 232 / 485 / 422 multiNet PROFIBUS PROFINET IO/RT Ethernet TCP/IP, UDP Ethernet IP	Integrated: RS 232 / 485 / 422 multiNet PROFIBUS PROFINET IO/RT Ethernet TCP/IP, UDP
	Connectivity		With MA 200i connection unit DeviceNet, CANopen	With MA 200i connection unit EtherCAT, DeviceNet, CANopen	With MA 200i connection unit EtherCAT, DeviceNet, CANopen
	Supply voltage	18–30 V DC	18–30 V DC	10–30 V DC	10–30 V DC
	Degree of protection	IP 65	IP 65	IP 65	IP 65
Network master		MA 31	Integrated	Integrated	
Certifications	CE CDRH	CE CDRH cUL US	CE CDRH cUL US	CE CDRH cUL US	
Accessories	Optional				
	Mounting devices	BT 56, BT 300W, BT 300-1	BT 56, BT 59, BT 300 W, BT 300	BT 56, BT 59	BT 56, BT 59
Properties	Optimized for constrained spaces between the conveyor lines Integrated fieldbus connectivity Code reconstruction technology (CRT) Simple configuration without additional software or GSDML file Connection type: cable tail with connector	Integrated fieldbus connectivity Code reconstruction technology (CRT) Available as a front scanner, deflecting mirror and oscillating mirror model Simple configuration without additional software via USB interface or GSD / GSDML file Modular connection type via M12 hood with integrated connectors, terminal hood or cable hood Optional with display and as heating model	“webConfig” software integrated in the device permits configuration via USB interface without additional software Multiple language menu-driven display M12 connection type Integrated fieldbus connectivity for convenient fieldbus link, networking and configuration via the GSD / GSDML file Code reconstruction technology (CRT) for reliable identification of damaged codes Optional heating models to –35 °C	“webConfig” software integrated in the device permits configuration via USB interface without additional software Multiple language menu-driven display M12 connection type Integrated fieldbus connectivity for convenient fieldbus link and networking Code reconstruction technology (CRT) for reliable identification of damaged codes Optimized for modules from 0.25 to 0.5 mm	

Stationary 2D-code readers



DCR 200i

Typical applications	Code reading	Data Matrix, bar code, QR-Code, Pharmacode, Aztec, GS1 Databar
	Sensor / cameras	CMOS (Global Shutter)
	Resolution (pixel)	1,280 × 960
	Focal point	U optics: 50 mm N optics: 70 mm M optics: 105 mm F optics: 185 mm L optics: 285 mm
	Interfaces	Integrated: Ethernet TCP/IP, UDP PROFINET IO/RT EtherNet/IP RS 232 RS 422
	Connectivity	With MA 200i connection unit PROFIBUS Ethernet TCP/IP, UDP EtherCAT DeviceNet CANopen
	Digital inputs/outputs	2 / 2
	Number of test routines	Memory capacity for 1 parameter set in the camera
	Configuration / Operating system	Configuration via configuration codes or via PC using standard web browser without software to be installed additionally (webConfig tool)
	Options	Optional: connection cables Optical filters Housing hoods External illumination Mounting devices: BTU 320M-D12, BT 320M MA 150 modular connection unit
	Dimensions, W × H × D	43 × 61 × 44 mm
	Certifications	CE cULus

Properties	Camera system for omnidirectional reading of bar codes, stacked codes and 2D-codes Integrated illumination (type-dependent: red or IR) High object speed of up to 7 m/s Integrated teach functions for simple adjustments via buttons Optional robust stainless steel housing Optional with NPN switching inputs/outputs Optionally with integrated heating for use to -30 °C
-------------------	---

Mobile code readers



IT 1470g, 1472g

**IT 1980i, 1981i
IT 1990i, 1991i**

Specifications	Reading method	Area imager	With Bluetooth	Area imager	With Bluetooth
	Reading distance	18–400 mm		0–16,000 mm	
	Interfaces	Integrated: RS 232 / USB Keyboard Wedge PS 2		Integrated: RS 232 / USB Keyboard Wedge PS 2	
	Connectivity	With MA 21 connection unit multiNet		With MA 21 connection unit multiNet	
		With MA 200i connection unit PROFINET IO/RT PROFIBUS Ethernet TCP/IP, UDP EtherCAT DeviceNet CANopen		With MA 200i connection unit PROFINET IO/RT PROFIBUS Ethernet TCP/IP, UDP EtherCAT DeviceNet CANopen	
	Accessories	Cable for: RS 232, USB, Keyboard-Wedge; desktop support, wall support, power supply unit		Cable for: RS 232, USB, Keyboard-Wedge; holder, power supply unit, base station	
	Supply voltage	4.5–5.5V DC		4.5–5.5V DC	
	Area of application	Degree of protection IP 41		Tough industrial use High-contrast codes Degree of protection IP 65 (IP 67)	
	Code types	Bar codes		Bar codes and 2D-codes	
	Certifications	CE		CE	

Properties	Large reading field for bar code detection Ergonomic and robust housing Operating temperature 0 °C ... +45 °C	Large reading field for detection of high-contrast codes Ergonomic and very robust housing for rough applications Operating temperature from -30 °C ... +50 °C (IT 1990i, IT 1980i), -20 °C ... +50 °C (IT 1991i, IT 1981i)
-------------------	---	---

RFID systems



RFI 32

RFM 32, 62

	RFI 32	RFM 32, 62	
Specifications	Working frequency	125 kHz	13.56 MHz
	Max. RFID reading distance	80 mm	400 mm
	Max. speed	6.0 m/s	6.0 m/s
	Interfaces	Integrated: RS 232	Integrated: RS 232
	Connectivity	With MA 21 connection unit multiNet With MA 200i connection unit PROFINET IO/RT PROFIBUS Ethernet TCP/IP, UDP EtherCAT DeviceNet EtherNet/IP CANopen	With MA 21 connection unit multiNet With MA 200i connection unit PROFINET IO/RT PROFIBUS Ethernet TCP/IP, UDP EtherCAT DeviceNet EtherNet/IP CANopen
	Function	RFID reading	RFID reading / writing
	Possible transponder types	– Disc – High temperature proof up to 200 °C	– Disc – High temperature proof up to 250 °C – Smart label
	Supply voltage	12–30V DC	12–30V DC
	Degree of protection	IP 65	IP 65 / IP 67
	Certifications	CE	CE
Properties	Compact RFID reading unit High degree of protection for tough industrial application Mounting also in between conveyor rollers	Compact RFID write/read unit High degree of protection for tough industrial application Mounting also in between conveyor rollers RFM 32 is also available as device with Ex certification	

Data transmission

Optical data transmission



DDLS 200

DDLS 500

	DDLS 200	DDLS 500	
Specifications	Operating range	120, 200, 300, 500 m	40, 120, 200 m
	Light source	Infrared LED	Infrared laser (laser class 1M)
	Transmission rate	2 Mbit/s	100 Mbit/s
	Interfaces	PROFIBUS CAN DeviceNet Interbus Rockwell DH+ or RIO RS 422	PROFINET EtherNet IP EtherNet TCP/IP EtherCAT UDP
	Degree of protection	IP 65	IP 65
	Supply voltage	18–30 V DC	18–30 V DC
	Operating temperature	–5 °C ... +50 °C (–30 °C ... +50 °C with heating)	–5 °C ... +50 °C (–35 °C ... +50 °C with heating)
	Certifications	CE cULus	CE CDRH cULus
Properties	No-contact, wear-free data transmission Integrated mounting and alignment plate Optionally with heating	Transparent, real-time transmission of all TCP/IP- and UDP-based protocols Very simple diagnosis of the transmission technology Pre-mounted and complete delivery of all mounting and alignment elements Integrated laser pointer for fast installation (available optionally) Simple remote diagnosis via web browser-based user interface (available optionally) Device models as PROFINET network participants	

Safety solutions

Efficient material flow and gapless safety

The increasing automation of processes places growing demands on safety concepts. Classic concepts such as muting are often pushed to their limits here, e.g. at transfer stations and material locks. Our innovative safety solutions guarantee gapless safety, efficient material flow and high availability of your system, even with automatic processes.

Access guarding on pallet magazines

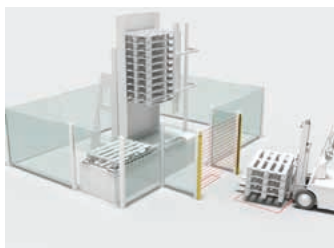

Access monitoring at material transfer station

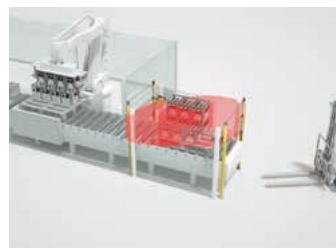

Access guarding on multi-track transport systems

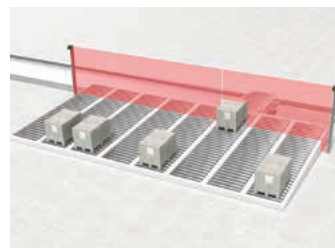

Area guarding at transverse transfer car systems

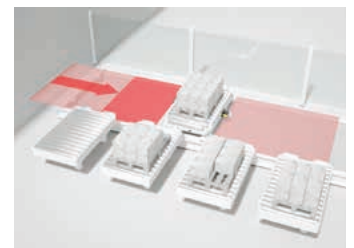

Advantages for you

- Save time and money with our pre-developed safety solutions
- All safety solutions are CE certified and compliant with standards. This gives you legal security.
- The intelligent and innovative safety concepts ensure smooth processes and seamless safety—even where classic concepts reach their limits
- Every safety solution is individually tailored to your system layout
- Our teams of certified safety experts are with you throughout the project

Benefit from our experience

- Innovative ideas are based on experience and know-how. For more than 30 years, we have been supporting safety-related applications in different industries by offering a broad range of products. Our safety experts have comprehensive knowledge of the latest norms and standards and extensive experience in designing safety concepts. This allows us to develop efficient safety solutions for use in automated environments.
- Global network of certified experts for the creation of safety concepts and the validation of the solutions on-site
 - In-house Solutions Engineering Center
 - Development and design according to the V-model in accordance with EN ISO 13849-1
 - Extensive selection of in-house safety products

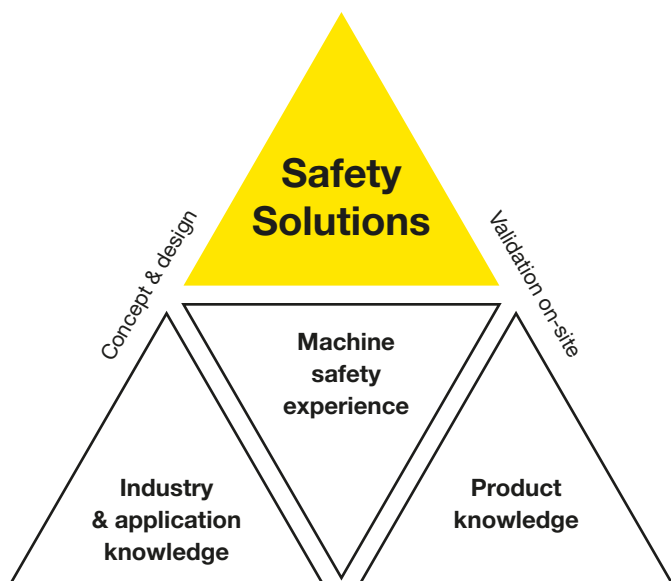

Complete solutions for your systems

Our solutions are based on qualified safety concepts which, if necessary, can also be extended or created new. We take care of all the necessary process steps, from standards research to start-up support. And in the project, each solution is individually adapted to your system layout.

Concept and design

The conceptualization and design of the safety solutions is carried out entirely by our Solutions Engineering Center.

This includes:

- Directives and standard research
- Creation of the safety concept and the system architecture
- Software development and validation
- Comprehensive documentation, including CE declaration of conformity



Services – Individual for your project

Each safety solution is individually adapted to your system and is supported by us in the project until handover:

- Engineering services with configuration according to project requirements
- Start-up support
- Final inspection



Hardware and software components

Our safety solutions include all the necessary hardware and software components for integration into your system:

- Safety sensors
- Safety control
- Leuze safety program
- Compact switch cabinet, as required
- Wiring

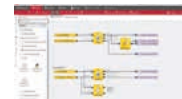

The path to your solution

Gather requirements

- Examine layout and danger zones, clarify processes
- Check risk assessment, define protective goals
- Clarify timing

Safety inspection and acceptance

- Validation of the safety function
- Initial inspection of the safety devices
- Creation of the acceptance documentation

Selection of the safety concept

- Evaluation of the requirements by our safety experts
- Selection of the appropriate safety concept and the required components

Installation and commissioning

- Provision of the mounting and installation instructions
- Mounting and installation of the system components
- Support during commissioning and the integration in the control

Configuration and parameterization

- Configuration of the safety system
- Programming and parameterization according to requirements
- Project-specific documentation

Machine Safety Services

Sustainable machine safety begins with professional planning of the safety systems and spans the entire lifecycle of a machine. Our teams of experienced and certified experts offer the appropriate support here.

Stages of a machine life cycle

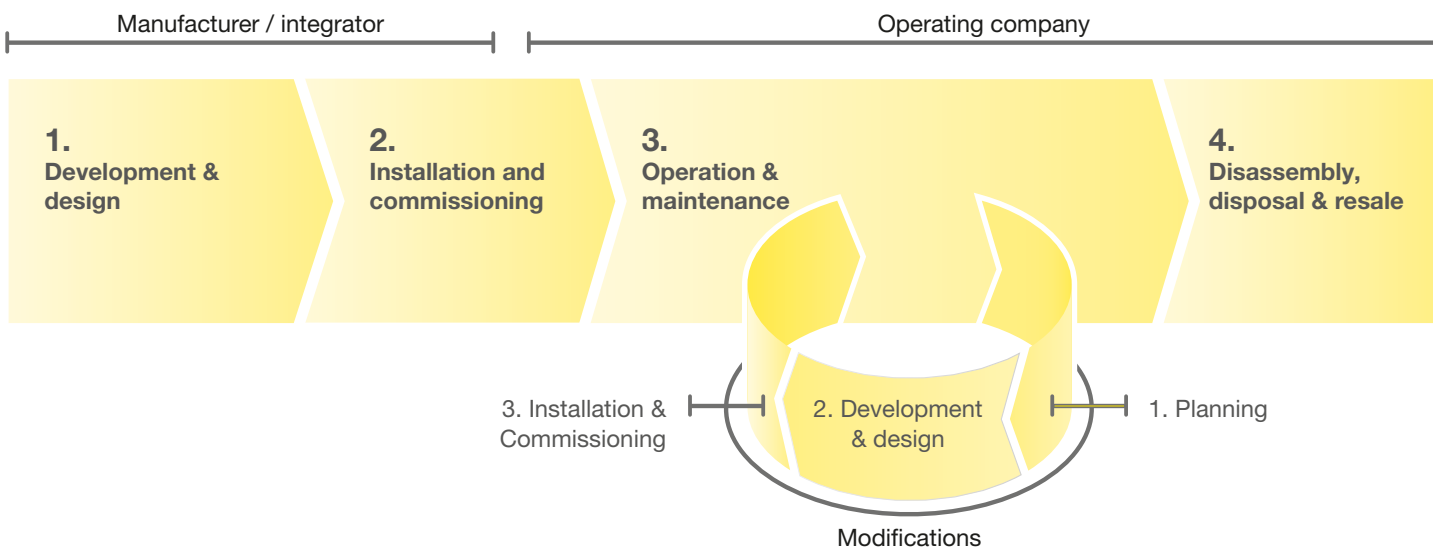

When designing and constructing machines, we create the safety-related concept together with you and support you in its realization. During operation, we regularly perform tests to ensure the permanent function of the safety systems. If changes are made to existing machines, we provide you with support on everything from the safety-related planning to renewed commissioning.

Through our services, you benefit from our many years of experience in the area of machine safety and our extensive industry and application knowledge. Efficient safety-related solutions for every phase of a machine's life cycle are thereby created together.

Our service offerings



Status check “safety technology on machines and systems”

- Our experts analyze the safety-related condition of your machinery and check whether the current safety-related requirements are satisfied in accordance with the current state of the art.
- In the event of deviations, we provide recommendations on what corrections can be performed so as to comply with legal requirements.



Risk assessment and hazard assessment

In accordance with applicable directives, the manufacturer of a machine is required to perform a risk assessment. This also applies in the case of significant modifications or extensions of machines.

The national regulations for the operation of machines require employers to conduct a hazard assessment before using work equipment and to update this assessment at regular intervals according to the current state of the art.

- Our experts support you in identifying the dangers, in assessing and evaluating the risks as well as in defining the risk-reducing measures.



Inspection of protective devices

- Within the scope of the initial or regular inspection, we check the condition, mounting and correct function of the protective device as well as the correct integration in the safe part of the machine control
- We summarize the results of the tests in a detailed report. If necessary, this includes practically oriented suggestions on how deviations can be corrected.



Stopping time measurement

For the correct placement of the protective device, the required minimum distance between protective device and dangerous movements is to be calculated. To do this, the stopping time of the machine must be known. With the stopping time measurement, we determine this value reliably.

- By measuring the stopping time within the scope of regular inspections, any wear, such in brake components, can be detected in good time.



Status check “CE marking of machines”

During the development of machines, the specifications from the machinery directive must be adhered to and documented by the manufacturer. This is confirmed with the Declaration of Conformity and the CE marking.

- We check the documentation for completeness and give recommendations of how any deviations can be corrected.

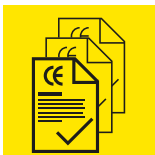

Conformity assessment in accordance with the European machinery directive

The machinery directive defines the procedure for the design and construction of machines for satisfying the applicable safety and health protection requirements. This is a prerequisite for the Declaration of Conformity and the CE marking.

- We help you comply with and implement the legal requirements of the machinery directive.



Safety concept and safety design

The measures necessary for risk minimization are known from the risk analysis.

The safety concept and the safety functions are developed on the basis of these requirements.

- With our extensive industry knowledge and our many years of safety-related experience, we create practically oriented concept proposals for you and support you during their implementation.



Verification and validation

To avoid errors during the implementation of safety functions, both the hardware as well as the software must be checked to determine whether the requirements of the functional specification were met completely and correctly. The function test of all safety functions is to be performed according to the validation plan.

- We support you during the planning, development and execution of the function tests as well as with the creation of the required documentation.

Accessories and supplementary products

Efficient work requires more than just a sensor. Almost as important are the appropriate accessories, which allow the sensor to utilize its full functionality. No matter if you need easy mounting, uncomplicated connection or reliable signaling, you can easily find the right accessories for your application in our extensive product range.

You can find our complete accessories range on our website at www.leuze.com.

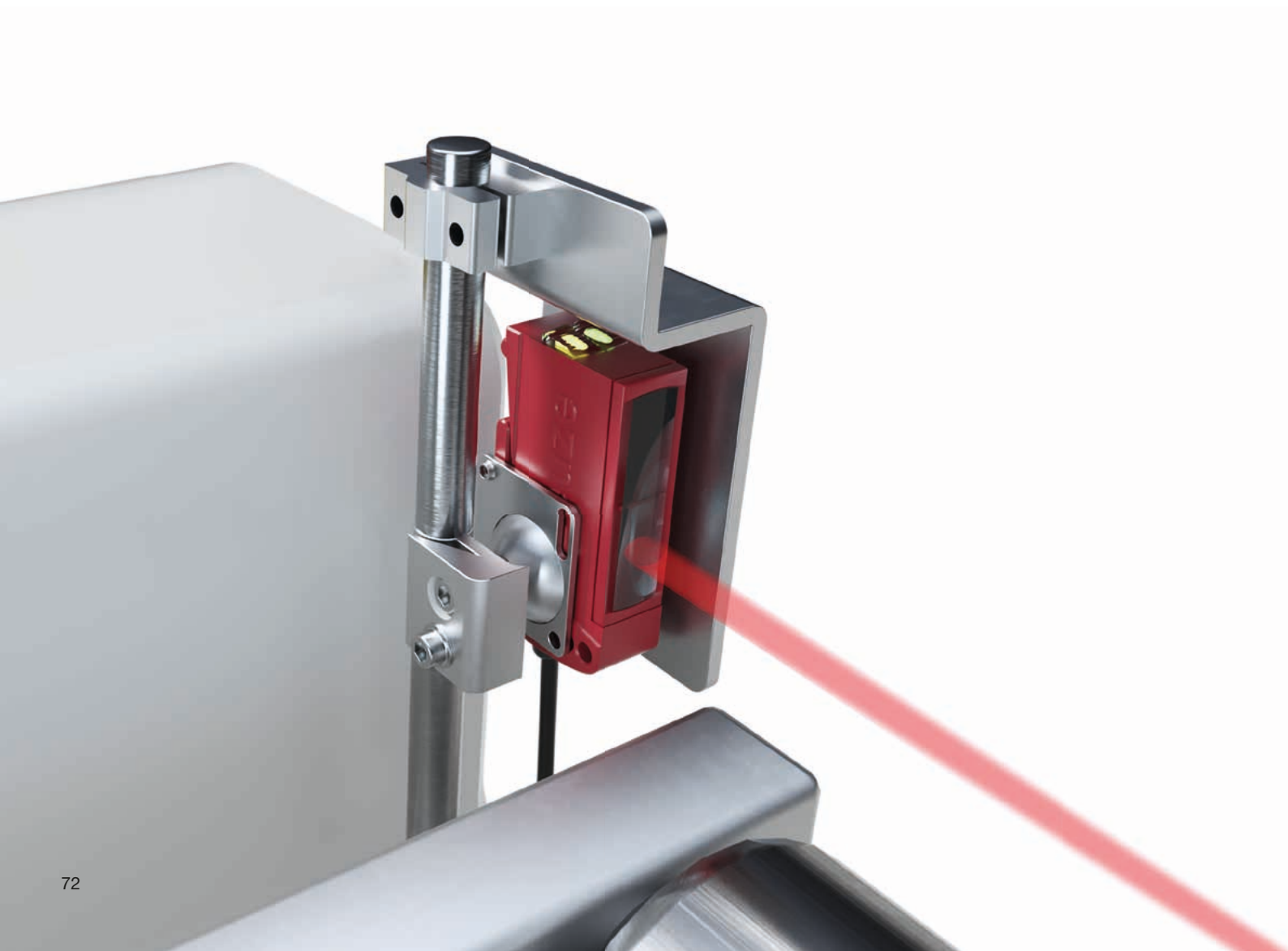



Mounting systems

We place great emphasis on our products being easy to mount and simple to align. For this reason, you will find specially-attuned mounting systems in our product range such as mounting brackets, rod holders or device columns.

Reflectors

Just how reliably retro-reflective photoelectric sensors can detect depends upon the selected reflector, among other things. That is why we offer various matching solutions made of plastic, film, and glass for all conceivable conditions.



Cables

To facilitate the integration of our sensors, we offer a large variety of connection and interconnection cables with M8, M12, and M23 connectors – straight or angled, and with or without LED.

Connection units

Today, sensors, safety switches and cameras are linked together via active or passive sensor distribution boxes with fieldbus interfaces from our product range to ensure more flexibility and transparency during installation.



Mounting brackets and device and mirror columns

The mounting brackets designed for our safety sensors ensure simple mounting and alignment of the devices. Device columns for free-standing floor assembly and mirror columns for multi-sided safeguarding simplify the installations.

Signaling devices

For signaling in automated systems, we offer an extensive product range of single- and multi-colored as well as acoustic transducers in order to ensure productivity and efficiency.



Our company

Everything at a glance

In a constantly changing industrial world, we work together with our customers to find the best solution for their sensor applications: innovatively, precisely and efficiently.

Key figures

Foundation	1963
Company structure	GmbH + Co. KG, wholly family-owned
Executive management	Ulrich Balbach
Headquarters	Owen, Germany
Distribution companies	21
Production locations	6
Technological competence centers	3
Distributors	40
Employees	1,400

Product range

- Switching sensors
- Measuring sensors
- Safety
- Identification
- Data transmission
- Network and connection technology
- Industrial image processing
- Accessories and supplementary products

Focus industries

- Intralogistics
- Packaging industry
- Machine tools
- Automotive industry
- Laboratory automation



Leuze electronic GmbH + Co. KG

In der Braike 1
73277 Owen
Phone: +49 7021 573-0
Fax: +49 7021 573-199
E-mail: info@leuze.com
www.leuze.com





Our Locations

At work for you around the world

Your success is our motivation. We therefore place great value on always being personally, quickly, and easily accessible to you. We produce on four continents, allowing us to offer you reliable product availability.

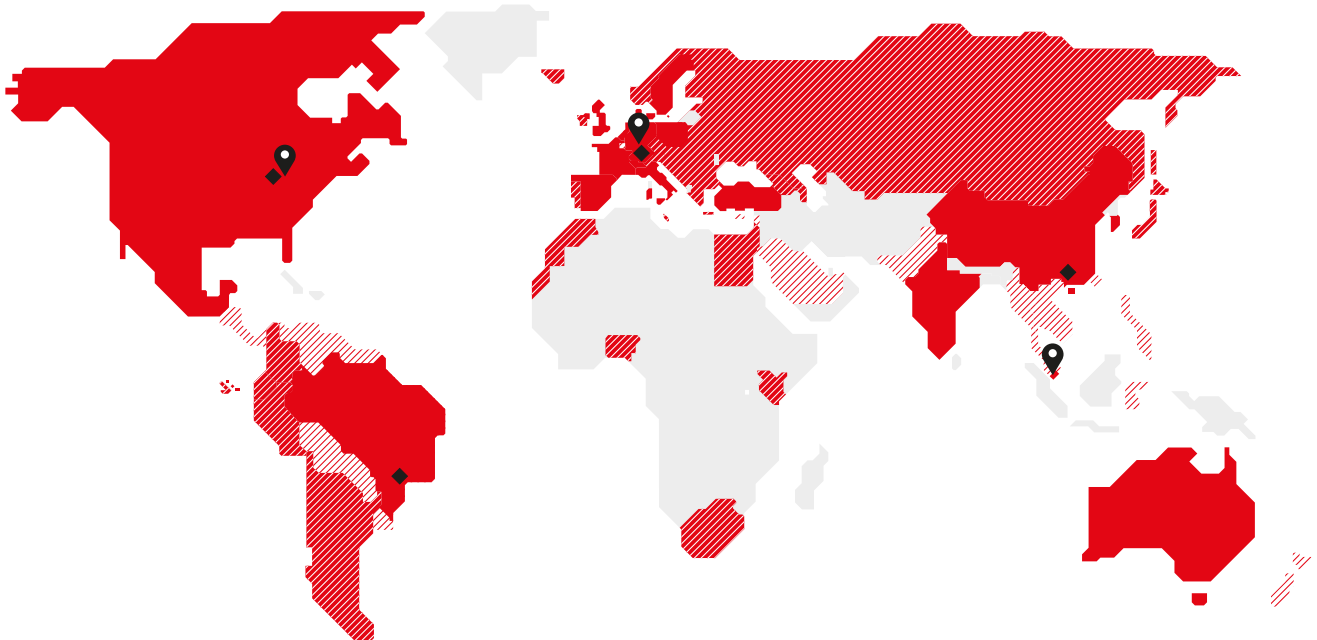

- 📍 Technological competence centers
- ◆ Production locations
- Distribution companies
- ▨ Distributor
- ▧ Distribution through neighboring country

Technological competence centers

Owen, Germany
New Hudson/Detroit, USA
Singapore

Production locations

Owen, Germany
Unterstadion, Germany
New Hudson/Detroit, USA
Shenzhen, China
São Paulo, Brazil
Malacca, Malaysia

Distribution companies

Australia/New Zealand
Belgium
Brazil
China
Denmark/Sweden
France
Germany – headquarters
Germany – distribution company
Great Britain
Hong Kong
India
Italy
Mexico
Poland
Singapore
South Korea
Spain
Switzerland
The Netherlands
Turkey
USA/Canada

Our product range at a glance

Switching Sensors

- Optical Sensors
- Inductive Switches
- Capacitive Sensors
- Ultrasonic Sensors
- Fiber Optic Sensors
- Fork Sensors
- Light Curtains
- Special Sensors

Measuring Sensors

- Distance Sensors
- Sensors for Positioning
- 3D Sensors
- Light Curtains
- Bar Code Positioning Systems
- Fork Sensors

Safety

- Safety Solutions
- Safety Laser Scanners
- Safety Light Curtains
- Single and Multiple Light Beam Safety Devices
- Safety Radar Sensors
- Safe Locking Devices, Switches and Proximity Sensors
- Safety PLCs and Relays
- Machine Safety Services

Identification

- Bar Code Identification
- 2D-Code Identification
- RF Identification

Data Transmission

- Optical Data Transmission Systems

Network and Connection Technology

- Connection Technology
- Modular Connection Units

Industrial Image Processing

- Light Section Sensors
- Smart Camera

Accessories and Supplementary Products

- Signaling Devices
- Mounting Systems
- Reflectors

Your contact with us

Leuze electronic GmbH + Co. KG

In der Braike 1, 73277 Owen

Phone +49 7021 573-0

Fax +49 7021 573-199

info@leuze.com

www.leuze.com