

# Absolute Encoders – Multiturn

<b>Standard mechanical Multiturn, optical</b>	<b>Sendix 5863 / 5883 (Shaft / Hollow shaft)</b>	<b>SSI / BiSS-C</b>
---	--	---------------------

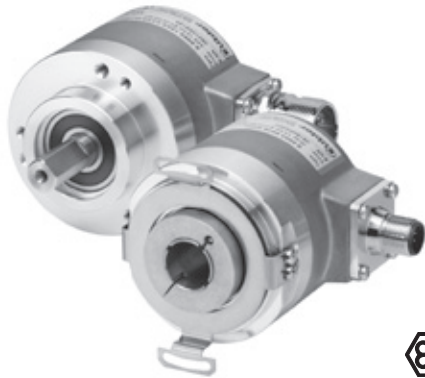

The Sendix 5863 and 5883 multiturn encoders with SSI or BiSS-C interface and optical sensor technology can achieve a resolution of max. 29 bits.

A through hollow shaft up to 14 mm and a blind hollow shaft up to 15 mm are available, as well as versions with additional SinCos or RS422 incremental track.



Mechanical drive	Safety-Lock™	High rotational speed	Temperature range -40°...+90°C	High protection level IP67	High shaft load capacity	Shock / vibration resistant	Magnetic field proof	Reverse polarity protection	SinCos	Seawater-resistant version on request

## Reliable

- Tried-and-tested in applications with the highest demands, such as in wind energy or mobile automation
- Absolutely reliable operation in areas with strong magnetic fields, thanks to mechanical gear with optical sensor technology
- Rugged die-cast housing, remains sealed even in harsh every-day use
- -40°C... +90°C: use in wide temperature range and protection IP67

## Versatile

- Available with SSI or BiSS-C interface and combined with SinCos incremental signals
- The right fixing solution or type of connection available for every application
- SET button and LED for simple start-up

Absolute Encoders  
Multiturn

## Order code Shaft version

**8.5863** . XXXX . XX2X  
Type                    a b c d e f g h

If for each parameter of an encoder the underlined preferred option is selected, then the delivery time will be 10 working days for a maximum of 10 pieces.  
Qts. up to 50 pcs. of these types generally have a delivery time of 15 working days.



### a Flange

- 1 = clamping flange, IP65 ø 58 mm [2.28"]
- 3 = clamping flange, IP67 ø 58 mm [2.28"]
- 2 = synchro flange, IP65 ø 58 mm [2.28"]
- 4 = synchro flange, IP67 ø 58 mm [2.28"]
- 5 = square flange, IP65 □ 63.5 mm [2.5"]
- 7 = square flange, IP67 □ 63.5 mm [2.5"]
  
- 6 = servo flange, IP65 ø 63.5 mm [2.5"]<sup>1)</sup>
- 8 = servo flange, IP67 ø 63.5 mm [2.5"]<sup>1)</sup>

### b Shaft (ø x L), with flat

- 1 = 6 x 10 mm [0.24 x 0.39"]<sup>2)</sup>
- 2 = 10 x 20 mm [0.39 x 0.79"]<sup>3)</sup>
- 3 = 1/4" x 7/8"
- 4 = 3/8" x 7/8"

### c Interface / Power supply

- 1 = SSI or BiSS-C / 5 V DC
- 2 = SSI or BiSS-C / 10 ... 30 V DC
- 3 = SSI or BiSS-C, 2048 ppr SinCos / 5 V DC
- 4 = SSI or BiSS-C, 2048 ppr SinCos / 10 ... 30 V DC
- 5 = SSI or BiSS-C / 5 V DC, with sensor output for monitoring the voltage on the encoder
- 6 = SSI or BiSS-C, 2048 ppr SinCos / 5 V DC, with sensor output for monitoring the voltage on the encoder
- 7 = SSI or BiSS-C and 2048 ppr incremental signals RS422 (TTL-comp.) / 5 V DC
- 8 = SSI or BiSS-C and 2048 ppr incremental signals RS422 (TTL-comp.) / 10 ... 30 V DC
- 9 = SSI or BiSS-C and 2048 ppr incremental signals RS422 (TTL-comp.) / 5 V DC, with sensor output for monitoring the voltage on the encoder

### d Type of connection

- 1 = axial cable, 1 m [3.28"] PVC
- 2 = radial cable, 1 m [3.28"] PVC
- 3 = M23 connector, 12-pin, axial
- 4 = M23 connector, 12-pin, radial
- 5 = M12 connector, 8-pin, axial<sup>4)</sup>
- 6 = M12 connector, 8-pin, radial<sup>4)</sup>

### e Code

- B = SSI, Binary
- C = BiSS-C, Binary
- G = SSI, Gray

### f Resolution<sup>5)</sup>

- A = 10 bit ST + 12 bit MT
- 1 = 11 bit ST + 12 bit MT
- 2 = 12 bit ST + 12 bit MT
- 3 = 13 bit ST + 12 bit MT
- 4 = 14 bit ST + 12 bit MT
- 7 = 17 bit ST + 12 bit MT

### g Inputs / Outputs<sup>5)</sup>

- 2 = SET, DIR input  
additional status output

### h Options (Service)

- 1 = no option
- 2 = Status LED
- 3 = SET button and Status LED

optional on request

- Ex 2/22
- seawater-resistant
- special cable length

1) US-Version

2) Preferred type only in conjunction with flange type 2

3) Preferred type only in conjunction with flange type 1

4) Uniquement avec interface 1 et 2

5) Resolution, preset value and counting direction factory-programmable

# Absolute Encoders – Multiturn

**Standard mechanical Multiturn, optical**

**Sendix 5863 / 5883 (Shaft / Hollow shaft)**

**SSI / BiSS-C**

**Order code Hollow shaft**

**8.5883** Type **.XXXX.XX2X**  
a b c d e f g h

If for each parameter of an encoder the underlined preferred option is selected, then the delivery time will be 10 working days for a maximum of 10 pieces. Qts. up to 50 pcs. of these types generally have a delivery time of 15 working days.



**a Flange**

- 1 = with spring element long, IP65
- 2 = with spring element long, IP67
- 3 = with stator coupling, IP65  $\varnothing$  65 mm [2.56"]
- 4 = with stator coupling, IP67  $\varnothing$  65 mm [2.56"]
- 5 = with stator coupling, IP65  $\varnothing$  63 mm [2.48"]
- 6 = with stator coupling, IP67  $\varnothing$  63 mm [2.48"]

**b Hollow shaft**

- 3 =  $\varnothing$  10 mm [0.39"]
- 4 =  $\varnothing$  12 mm [0.47"]
- 5 =  $\varnothing$  14 mm [0.55"]
- 6 =  $\varnothing$  15 mm [0.59"] – blind hollow shaft
- 8 =  $\varnothing$  3/8"
- 9 =  $\varnothing$  1/2"

**c Interface / Power supply**

- 1 = SSI or BiSS-C / 5 V DC
- 2 = SSI or BiSS-C / 10 ... 30 V DC
- 3 = SSI or BiSS-C, 2048 ppr SinCos / 5 V DC
- 4 = SSI or BiSS-C, 2048 ppr SinCos / 10 ... 30 V DC
- 5 = SSI or BiSS-C / 5 V DC, with sensor output for monitoring the voltage on the encoder
- 6 = SSI or BiSS-C, 2048 ppr SinCos / 5 V DC, with sensor output for monitoring the voltage on the encoder
- 7 = SSI or BiSS-C and 2048 ppr incremental signals RS422 (TTL-comp.) / 5 V DC
- 8 = SSI or BiSS-C and 2048 ppr incremental signals RS422 (TTL-comp.) / 10 ... 30 V DC
- 9 = SSI or BiSS-C and 2048 ppr incremental signals RS422 (TTL-comp.) / 5 V DC, with sensor output for monitoring the voltage on the encoder

**d Type of connection**

- 2 = axial cable, 1 m [3.28"] PVC
- 4 = M23 connector, 12-pin, radial
- 6 = M12 connector, 8-pin, radial <sup>2)</sup>
- E = tangential cable, 1 m [3.28"] PVC

**e Code**

- B = SSI, Binary
- C = BiSS-C, Binary
- G = SSI, Gray

**f Resolution <sup>1)</sup>**

- A = 10 bit ST + 12 bit MT
- 1 = 11 bit ST + 12 bit MT
- 2 = 12 bit ST + 12 bit MT
- 3 = 13 bit ST + 12 bit MT
- 4 = 14 bit ST + 12 bit MT
- 7 = 17 bit ST + 12 bit MT

**g Inputs / Outputs <sup>1)</sup>**

- 2 = SET, DIR input additional status output

**h Options (Service)**

- 1 = no option
- 2 = Status LED
- 3 = SET button and Status LED

optional on request  
 - Ex 2/22  
 - seawater-resistant  
 - special cable length

**Mounting accessory for shaft encoders**

Order No.

**Coupling**

- Bellows coupling  $\varnothing$  19 mm [0.75"] for shaft 6 mm [0.24"]
- Bellows coupling  $\varnothing$  19 mm [0.75"] for shaft 10 mm [0.39"]

**8.0000.1101.0606**  
**8.0000.1101.1010**

**Mounting accessory for hollow shaft encoders**

**Cylindrical pin, long**

for torque stops

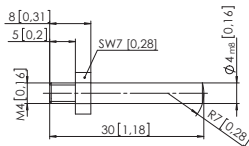

With fixing thread

**8.0010.4700.0000**

**Connection technology**

**Connector, self-assembly (straight)**

- M12 female connector with coupling nut
- M23 female connector with coupling nut

**05.CMB 8181-0**  
**8.0000.5012.0000**

**Cordset, pre-assembled**

- M12 female connector with coupling nut, 2 m [6.56'] PVC cable
- M23 female connector with coupling nut, 2 m [6.56'] PVC cable

**05.00.6041.8211.002M**  
**8.0000.6901.0002.0031**

Further accessories can be found in the accessories section or in the accessories area of our website at: [www.kuebler.com/accessories](http://www.kuebler.com/accessories)  
 Additional connectors can be found in the connection technology section or in the connection technology area of our website at: [www.kuebler.com/connection\\_technology](http://www.kuebler.com/connection_technology)

1) Resolution, preset value and counting direction factory-programmable  
 2) Only in conjunction with flange type 1 and 2

# Absolute Encoders – Multiturn

<b>Standard mechanical Multiturn, optical</b>	<b>Sendix 5863 / 5883 (Shaft / Hollow shaft)</b>	<b>SSI / BiSS-C</b>
---	--	---------------------

## Technical data

Mechanical characteristics		
<b>Max. speed, shaft version</b>	IP65 up to 70°C [158°F]	12 000 min <sup>-1</sup> , 10 000 min <sup>-1</sup> (continuous)
	IP65 up to T <sub>max</sub>	8 000 min <sup>-1</sup> , 5 000 min <sup>-1</sup> (continuous)
	IP67 up to 70°C [158°F]	11 000 min <sup>-1</sup> , 9 000 min <sup>-1</sup> (continuous)
<b>Max. speed, hollow shaft version</b>	IP65 up to 70°C [158°F]	9 000 min <sup>-1</sup> , 6 000 min <sup>-1</sup> (continuous)
	IP65 up to T <sub>max</sub>	6 000 min <sup>-1</sup> , 3 000 min <sup>-1</sup> (continuous)
	IP67 up to 70°C [158°F]	8 000 min <sup>-1</sup> , 4 000 min <sup>-1</sup> (continuous)
<b>Starting torque at 20°C [68°F]</b>	IP65	< 0.01 Nm
	IP67	< 0.05 Nm
<b>Moment of inertia</b>	shaft version	4.0 x 10 <sup>-6</sup> kgm <sup>2</sup>
	hollow shaft version	7.0 x 10 <sup>-6</sup> kgm <sup>2</sup>
<b>Load capacity of shaft</b>	radial	80 N
	axial	40 N
<b>Weight</b>	approx. 0.45 kg [15.87 oz]	
<b>Protection acc. to EN 60529</b>	housing side	IP67
	shaft side	IP65, opt. IP67
<b>EX approval for hazardous areas</b>	optional Zone 2 and 22	
<b>Working temperature range</b>	-40°C ... +90°C <sup>1)</sup> [-40°F ... +194°F] <sup>1)</sup>	
<b>Material</b>	shaft/hollow shaft	stainless steel
	flange	aluminium
	housing	zinc die-cast housing
	cable	PVC
<b>Shock resistance acc. EN 60068-2-27</b>	2500 m/s <sup>2</sup> , 6 ms	
<b>Vibration resistance acc. EN 60068-2-6</b>	100 m/s <sup>2</sup> , 55 ... 2000 Hz	

Electrical characteristics		
<b>Power supply</b>	5 V DC + 5% or 10 ... 30 V DC	
<b>Current consumption (no load)</b>	5 V DC	max. 80 mA
	10 ... 30 V DC	max. 50 mA
<b>Reverse polarity protection of the power supply (+V)</b>	yes (at 10 ... 30 V DC)	
<b>Short circuit proof outputs</b>	yes <sup>2)</sup>	
<b>UL approval</b>	File 224618	
<b>CE compliant acc. to</b>	EMC guideline 2004/108/EC	
<b>RoHS compliant acc. to</b>	guideline 2011/65/EU	

SSI interface		
<b>Output driver</b>	RS485 transceiver type	
<b>Permissible load / channel</b>	max. 20 mA	
<b>Signal level</b>	HIGH	typ. 3.8 V
	LOW at I <sub>Load</sub> = 20 mA	typ. 1.3 V
<b>Singleturn resolution</b>	10 ... 14 bit and 17 bit <sup>3)</sup>	
<b>Number of revolutions</b>	4096 (12 bit)	
<b>Code</b>	Binary or Gray	
<b>SSI clock rate</b>	ST resolution ≤ 14 bit	50 kHz ... 2 MHz
	ST resolution ≥ 15 bit	50 kHz ... 125 kHz
<b>Monoflop time</b>	≤ 15 μs	
Note: If the clock starts cycling within the monoflop time, a second data transfer starts with the same data. If the clock starts cycling after the monoflop time, the data transfer starts with the new values. The update rate is dependent on the clock speed, data length and monoflop-time.		
<b>Data refresh rate</b>	ST resolution ≤ 14 bit	≤ 1 μs
	ST resolution ≥ 15 bit	4 μs
<b>Status and parity bit</b>	on request	

BiSS-C Interface		
<b>Singleturn resolution</b>	10 ... 14 bit and 17 bit <sup>3)</sup>	
<b>Number of revolutions</b>	4096 (12 bit)	
<b>Code</b>	Binary	
<b>Clock rate</b>	50 kHz ... 10 MHz	
<b>Max. update rate</b>	< 10 μs, depends on the clock rate and the data length	
<b>Data refresh rate</b>	≤ 1 μs	
<b>Note:</b>	<ul style="list-style-type: none"> <li>- Bidirectional, factory programmable parameters are: resolution, code, direction, alarms and warnings</li> <li>- CRC data verification</li> </ul>	

SET input or SET button		
<b>Input</b>	active HIGH	
<b>Input type</b>	comparator	
<b>Signal level</b>	HIGH	min: 60 % of +V (power supply) max: +V
	LOW	max: 25 % of +V (power supply)
<b>Input current</b>	< 0.5 mA	
<b>Min. pulse duration (SET)</b>	10 ms	
<b>Timeout after SET signal</b>	14 ms	
<b>Response time (DIR input)</b>	1 ms	

The encoder can be set to zero at any position by means of a HIGH signal on the SET input or by pressing the optional SET button (with a pencil, ball-point pen or similar).

Other preset values can be factory-programmed. The SET input has a signal processing time of approx. 1 ms. Once the SET function has been triggered, the encoder requires an internal processing time of approx. 15 ms before the new position data can be read. During this time the status output is at LOW.

Option incremental outputs (A/B), 2048 ppr		
	SinCos	RS422 TTL-compatible
<b>Max. frequency -3dB</b>	400 kHz	400 kHz
<b>Signal level</b>	1 V <sub>pp</sub> (± 20%)	HIGH: min. 2.5 V LOW: max. 0.5 V
<b>Short circuit proof</b>	yes	yes

1) Cable version: -30°C ... +75°C [-22°F ... +167°F]  
 2) Short circuit to 0V or to output, one channel at a time, power supply correctly applied  
 3) Other options on request

# Absolute Encoders – Multiturn

<b>Standard mechanical Multiturn, optical</b>	<b>Sendix 5863 / 5883 (Shaft / Hollow shaft)</b>	<b>SSI / BiSS-C</b>
---	--	---------------------

Status output and LED	
<b>Output driver</b>	Open Collector, internal pull up resistor 22 kOhm
<b>Permissible load</b>	max. 20 mA
<b>Signal level</b>	HIGH: +V / LOW: < 1 V
<b>Active</b>	LOW
The optional LED (red) and the status output serve to display various alarm or error messages. In normal operation the LED is OFF and the status output is HIGH (Open Collector with int. pull-up 22k).	
An active status output (LOW) displays: <ul style="list-style-type: none"> <li>– Sensor error, singleturn or multiturn (soiling, glass breakage etc.)</li> <li>– LED fault (failure or ageing)</li> <li>– over- or under-temperature</li> </ul>	
In the SSI mode, the fault indication can only be reset by switching off the power-supply to the device.	

DIR input
A HIGH signal switches the direction of rotation from the default CW to CCW. This function can also be factory-programmed to be inverted. If DIR is changed when the device is already switched on, then this will be interpreted as an error. The LED will come ON and the status output will switch to LOW.

Power-on delay
After Power-ON the encoder requires a time of approx. 150 ms before valid data can be read.

### Terminal assignment

Interface	Type of connection	Features	Cable (Isolate unused wires individually before initial start-up)
1, 2	1, 2, E	SET, DIR, Status	Signal: 0 V +V C+ C- D+ D- SET DIR Stat N/C N/C N/C $\perp$
			Cable colour: WH BN GN YE GY PK BU RD BK - - - shield
1, 2	3, 4	SET, DIR, Status	M23 connector
			Signal: 0 V +V C+ C- D+ D- SET DIR Stat N/C N/C N/C $\perp$
5	1, 2, E	SET, DIR, Status sensor output	Cable (Isolate unused wires individually before initial start-up)
			Signal: 0 V +V C+ C- D+ D- SET DIR Stat N/C 0Vsens +Vsens $\perp$
5	3, 4	SET, DIR, Status sensor output	M23 connector
			Signal: 0 V +V C+ C- D+ D- SET DIR Stat N/C 0Vsens +Vsens $\perp$
3, 4, 7, 8	1, 2, E	SET, DIR, SinCos or incr. RS422	Cable (Isolate unused wires individually before initial start-up)
			Signal: 0 V +V C+ C- D+ D- SET DIR A $\bar{A}$ B $\bar{B}$ $\perp$
3, 4, 7, 8	3, 4	SET, DIR, SinCos or incr. RS422	M23 connector
			Signal: 0 V +V C+ C- D+ D- SET DIR A $\bar{A}$ B $\bar{B}$ $\perp$
6, 9	1, 2, E	SinCos o. incr. RS422 sensor output	Cable (Isolate unused wires individually before initial start-up)
			Signal: 0 V +V C+ C- D+ D- A $\bar{A}$ B $\bar{B}$ 0Vsens +Vsens $\perp$
6, 9	3, 4	SinCos o. incr. RS422 sensor output	M23 connector
			Signal: 0 V +V C+ C- D+ D- A $\bar{A}$ B $\bar{B}$ 0Vsens +Vsens $\perp$
1, 2	5, 6	SET, DIR	M12 connector
			Signal: 0 V +V C+ C- D+ D- SET DIR $\perp$

- +V: Encoder power supply +V DC
- 0 V: Encoder power supply ground GND (0 V)
- 0 Vsens / +Vsens: Using the sensor outputs of the encoder, the voltage present can be measured and if necessary increased accordingly.
- C+, C-: Clock signal
- D+, D-: Data signal
- A,  $\bar{A}$ : Incremental output channel A
- B,  $\bar{B}$ : Incremental output channel B

- SET: SET input. The current position becomes defined as position zero.
- DIR: Direction input: If this input is active, output values are counted backwards (decrease) when the shaft is turning clockwise.
- Stat: Status output
- PH  $\perp$ : Plug connector housing (Shield)

### Top view of mating side, male contact base



M12 connector, 8-pin

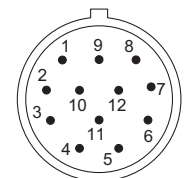

M23 connector, 12-pin

# Absolute Encoders – Multiturn

**Standard**  
mechanical Multiturn, optical

Sendix 5863 / 5883 (Shaft / Hollow shaft)

SSI / BiSS-C

## Dimensions shaft version

Dimensions in mm [inch]

### Clamping flange, $\varnothing$ 58 [2.28]

#### Flange type 1 and 3

(Drawing with M23 connector)

- 1 3 x M3, 6 [0.24] deep
- 2 3 x M4, 8 [0.32] deep

D	L	Fit
6 [0.24]	10 [0.39]	h7
10 [0.39]	20 [0.79]	f7
1/4"	7/8"	h7
3/8"	7/8"	h7

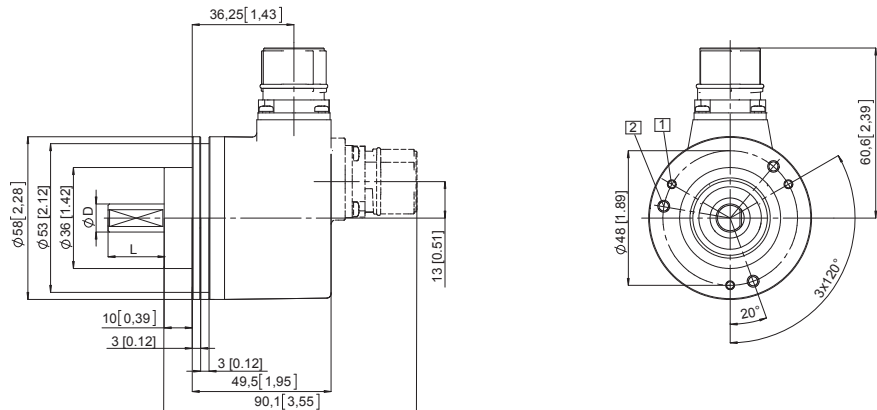

### Synchro flange, $\varnothing$ 58 [2.28]

#### Flange type 2 and 4

(Drawing with M12 connector)

- 1 M4, 6 [0.24] deep

D	L	Fit
6 [0.24]	10 [0.39]	h7
10 [0.39]	20 [0.79]	f7
1/4"	7/8"	h7
3/8"	7/8"	h7

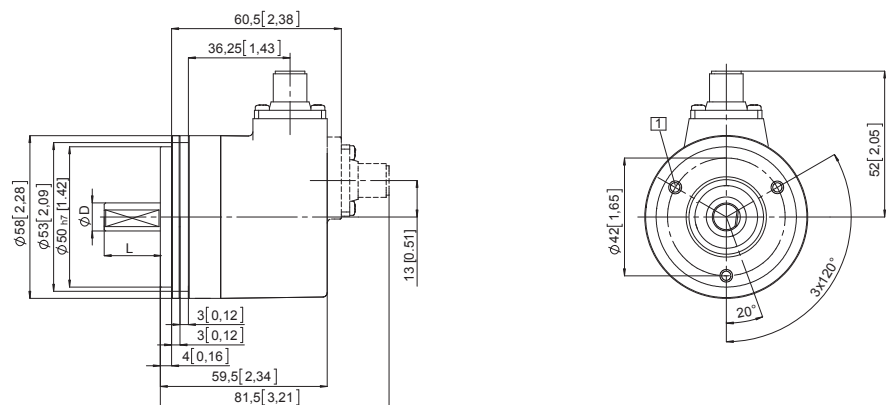

### Square flange, $\square$ 63.5 [2.5]

#### Flange type 5 and 7

(Drawing with cable)

D	L	Fit
6 [0.24]	10 [0.39]	h7
10 [0.39]	20 [0.79]	f7
1/4"	7/8"	h7
3/8"	7/8"	h7

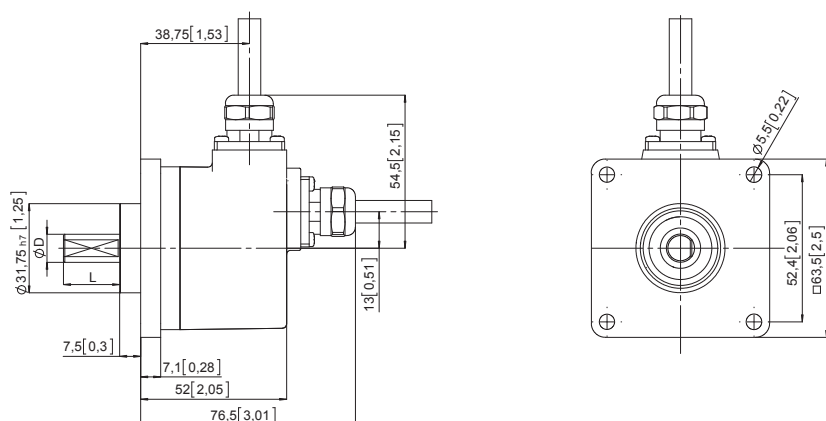

# Absolute Encoders – Multiturn

**Standard  
mechanical Multiturn, optical**

**Sendix 5863 / 5883 (Shaft / Hollow shaft)**

**SSI / BiSS-C**

## Dimensions hollow shaft version

Dimensions in mm [inch]

### Flange with spring element long

#### Flange type 1 and 2

(drawing with M12 connector)

- 1 Torque stop slot,  
Recommendation:  
Cylindrical pin DIN 7,  $\varnothing$  4 [0.16]
- 2 M3, 6 [0.24] deep
- 3 Recommended torque for the  
clamping ring 0.6 Nm

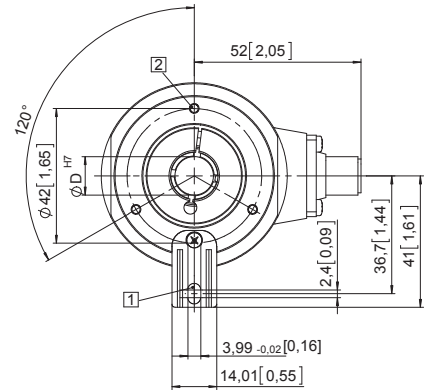
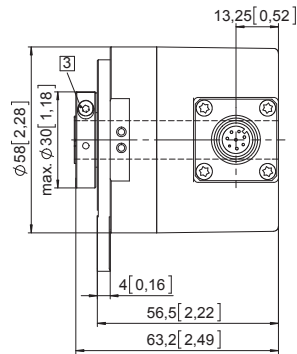

### Flange with spring element long

#### Flange type 1 and 2

(drawing with tangential cable)

- 1 Torque stop slot,  
Recommendation:  
Cylindrical pin DIN 7,  $\varnothing$  4 [0.16]
- 2 M3, 5.5 [0.21] deep
- 3 Status-LED
- 4 SET button
- 5 Recommended torque for the  
clamping ring 0.6 Nm

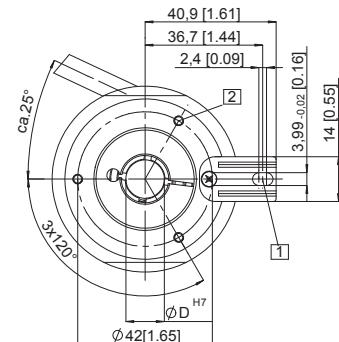
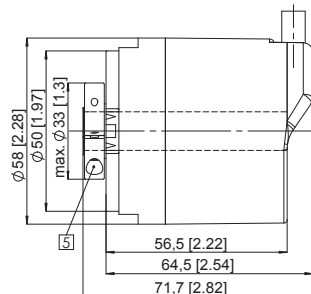
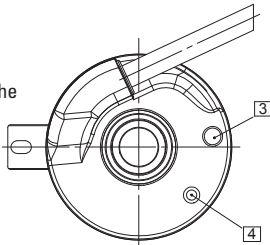

# Absolute Encoders – Multiturn

<b>Standard mechanical Multiturn, optical</b>	<b>Sendix 5863 / 5883 (Shaft / Hollow shaft)</b>	<b>SSI / BiSS-C</b>
---	--	---------------------

## Dimensions hollow shaft version

Dimensions in mm [inch]

### Flange with stator coupling, $\varnothing$ 63 [2.48]

#### Flange type 5 and 6

Pitch circle diameter for fixing screws 63 [2.48]

(Drawing with M23 connector)

- 1 Fixing screws DIN 912 M3 x 8  
(Washer included in delivery)
- 2 Recommended torque for the  
clamping ring 0.6 Nm

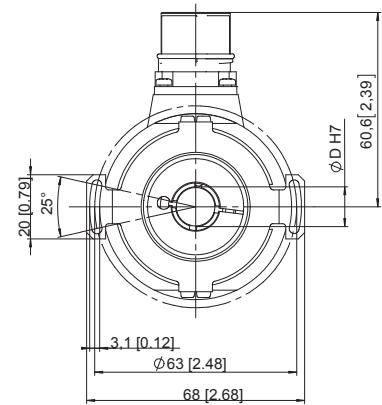
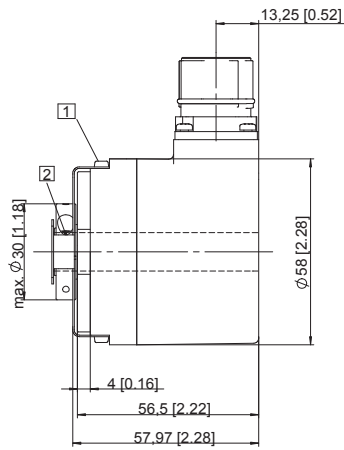

### Flange with stator coupling, $\varnothing$ 65 [2.56]

#### Flange type 3 and 4

Pitch circle diameter for fixing screws 65 [2.56]

(Drawing with cable)

- 1 Recommended torque for the  
clamping ring 0.6 Nm

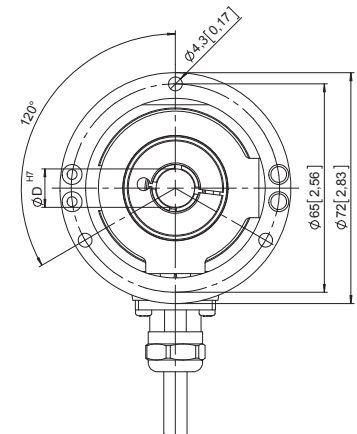
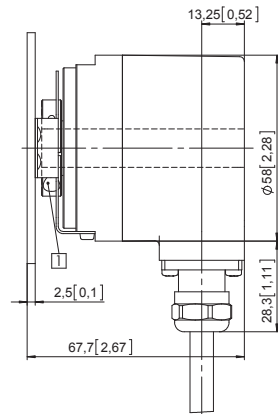

Absolute Encoders  
Multiturn