



Rectangular Photoelectric Sensor

BJ Series (Connector Type)

PRODUCT MANUAL

Be sure to follow the instructions and precautions in the instruction manual, other manuals, and the Autonics website.

The specifications, dimensions, and other information in this document are subject to change without notice for product improvement. Certain models may be discontinued without notice.

Safety Precautions

- 'Safety Precautions' are provided to ensure safe and proper use of the product and to prevent accidents or hazards. Please make sure to follow them carefully.
- ⚠ symbol indicates a caution, warning of potential hazards under certain conditions..

⚠ Warning Failure to follow instructions may result in serious injury or death.

01. Fail-safe device must be installed when using the product in applications that may cause serious injuries or property loss. (E.g. nuclear control systems, medical equipment, ships, vehicles, railroads, aircraft, combustion devices, safety devices, security systems, disaster prevention devices, etc.)

Failure to do so may result in personal injury, property loss or fire.

02. Do not use or store the product in environments containing flammable, explosive, or corrosive gases, or in places exposed to high humidity, direct sunlight, radiant heat, vibration, shock, or salt.

Failure to do so may result in explosion or fire.

03. Do not disassemble, repair, or modify the product without authorization.

Failure to do so may result in fire.

04. Do not connect, repair, or inspect the product while connected to a power source.

Failure to do so may result in fire.

05. Check the connection diagram before wiring.

Failure to do so may result in fire.

⚠ Caution Failure to follow instructions may result in injury or product damage.

01. Use the product within its rated specifications and performance limits.

Failure to do so may result in fire or product damage.

02. Use a dry cloth to clean the product. Do not use water or organic solvents.

Failure to do so may result in fire.

Cautions During Use

- Make sure to follow the instructions in 'Cautions During Use'. Failure to do so may result in unexpected accidents.
- When connecting inductive loads such as DC relays or solenoid valves use a diode, varistor, or similar component to suppress surges.
- Wait at least 0.5 seconds after applying power before using the product. When using separate power supplies for sensor and load, apply power to the sensor first.
- Power input should be supplied from an isolated and limited voltage/current source, or from a Class 2 or SELV power supply.
- To prevent surges and inductive noise, separate the wiring from high-voltage and power lines, and keep wiring lengths as short as possible.
- When supplying power with an SMPS, ground the F.G. terminal and connect a noise suppression capacitor between the 0 V and F.G. terminals.
- When using the product with noise-generating devices (e.g. switching regulators, inverters, servo motors, etc.), make sure to ground the F.G. terminal of the unit.
- This product may be used in the following environmental conditions.
 - Indoors (within rated environmental performance specifications)
 - Altitude: up to 2,000 m
 - Pollution Degree 3
 - Installation Category II

Ordering Information

For reference only. The actual product does not support all combinations.
To check all supported models, please refer to the Autonics website.

BJ ① - ② ③ ④ - ⑤ - ⑥

① Sensing distance

Number: Sensing distance (unit: mm)
Number+M: Sensing distance (unit: m)

② Sensing type

T: Through-beam
P: Polarized retroreflective
D: Diffuse reflective

③ Power supply

D: 12 - 24 VDC

④ Output

T: Solid state (transistor)

⑤ Connection

C: Connector type

⑥ Control output

No mark: NPN open collector output
P: PNP open collector output

Product Components

Sensing type	Through-beam	Polarized retroreflective	Diffuse reflective
Product components	Product, instruction manual		
Reflector	-	MS-2A	-
Adjustment screwdriver	× 1	× 1	× 1
Bracket B	× 2	× 1	× 1
M3 bolt / nut	× 4	× 2	× 2

Sold Separately

- Reflector: MS Series
- Bracket A
- Retroreflective tape: MST Series
- M8 connector cable: CID(H)408-□, CLD(H)408-□

Cautions During Installation

- Be sure to install this product by following the usage environment, location, and specified ratings. Consider the listed conditions below.
 - Installation environment and background (reflected light)
 - Sensing distance and sensing target
 - Direction of target's movement
 - Characteristic curves
- When installing multiple sensors closely, mutual interference may cause malfunction.
- For installation, tighten the screw with a torque of 0.5 N·m. Mount the brackets correctly to prevent the twisting of the sensor's optical axis.
- Do not impact with a hard object or bend the cable excessively. That could decrease the product's water resistance.
- Use the product after testing. Check whether the indicator works appropriately for the positions of the detectable object.

Through-beam	Retroreflective	Reflective
Emitter - Receiver: Install to face each other	Sensor - Reflector: At least 0.1 m apart, install facing each other (parallel with the sensing side of the unit)	Sensor - Sensing target: Install to face each other (parallel with the sensing side of the unit)

Connections



Pin	Color	Function
①	Brown	+V
②	-	-
③	Blue	0V
④	Black	OUT

- Connector pin ② is not used for the emitter units.
- Refer to the 'Circuit Diagram' for load connection.

Circuit Diagram

NPN Open Collector Output

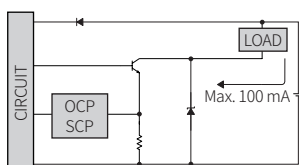

PNP Open Collector Output

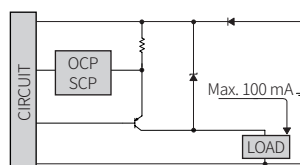

- OCP (over current protection), SCP (short circuit protection)
- If short-circuit the control output terminal or supply current over the rated specification, normal control signal is not output due to the protection circuit.

Setting Operation Mode

- Be sure to set the mode before power-on.
- Use the offered adjustment screwdriver. Do NOT turn with excessive force to prevent product damage.

L: Light ON mode	D: Dark ON mode

Operation Timing Chart and Indicators

Light ON Mode

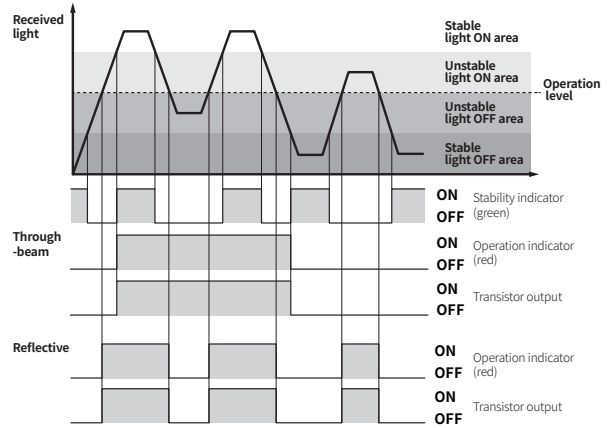

- In Dark ON mode, the waveforms are reversed.
- Operation indicator and transistor output differ from the sensing method.

Dimensions

- Unit: mm (Refer to the CAD files from the Autonics website for exact dimensions)

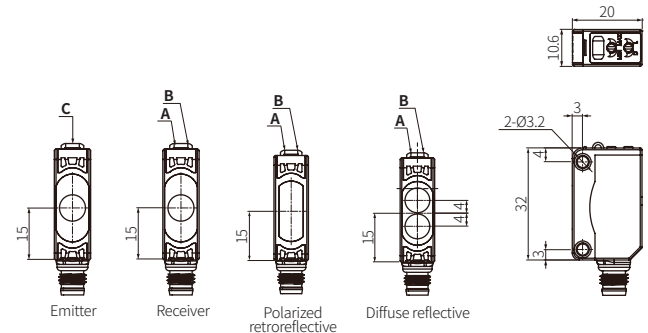

A	Operation indicator (red)	C	Power indicator (green)
B	Stability indicator (green)		

Reflector (MS-2A)

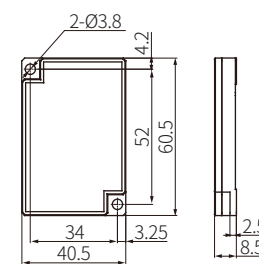

Bracket B (BJ BRACKET B)

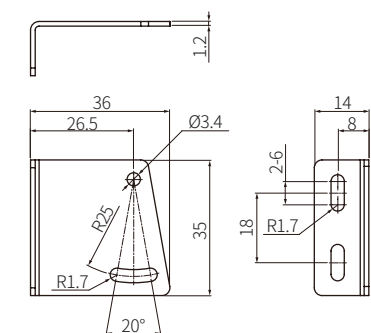

Sensitivity Adjustment

- Set the adjuster for stable Light ON area, minimizing the effect of the installation environment.
- Use the offered adjustment screwdriver. Do NOT turn with excessive force to prevent product damage.
- The steps below are based on Light ON mode.

Steps	Status	Description
01	Received	Turn the adjuster from MIN to MAX sensitivity and check the position (A) where the operation indicator activates under the light ON area.
02	Interrupted	Turn the adjuster from (A) to MAX and check the position (B) where the operation indicator activates under the light OFF area. If the operation indicator does NOT activate at the MAX (maximum sensitivity): MAX = (B).
03	-	Set the adjuster at the mid position between (A) and (B) for optimal sensitivity.

Specifications

Model	BJ□-TDT-C-□	BJ3M-PDT-C-□	BJ□-DDT-C-□
Sensing type	Through-beam	Polarized retroreflective	Diffuse reflective
Sensing distance	10 m 15 m	3 m ⁽⁰¹⁾	100 mm ⁽⁰²⁾ 300 mm ⁽⁰³⁾ 1 m ⁽⁰³⁾
Sensing target	Opaque materials	Opaque materials	Opaque materials, translucent materials
Min. sensing target	≥ Ø 12 mm	≥ Ø 75 mm	-
Hysteresis	-	-	≤ 20% of sensing distance
Response time	≤ 1 ms	≤ 1 ms	≤ 1 ms
Light source	Red Infrared	Red	Infrared Red Infrared
Peak emission wavelength	660 nm 850 nm	660 nm	850 nm 660 nm 850 nm
Sensitivity adjustment	YES (Adjuster)	YES (Adjuster)	YES (Adjuster)
Mutual interference prevention	-	YES	YES
Operation mode	Light ON mode - Dark ON mode selectable (Adjuster)		
Indicator	Operation indicator (red), stability indicator (green), power indicator (green) ⁽⁰⁴⁾		
Certification	CE	CE	CE
Unit weight (packaged)	≈ 20 g (≈ 45 g)	≈ 30 g (≈ 55 g)	≈ 10 g (≈ 35 g)

01) Reflector (MS-2A)

02) Non-glossy white paper 100 × 100 mm

03) Non-glossy white paper 300 × 300 mm

04) Only for the emitter

Power supply	12-24 VDC≡ ±10% (ripple P-P: ≤ 10%)
Current consumption	It depends on the sensing type
Through-beam	Emitter: ≤ 20 mA, receiver: ≤ 20 mA
Reflective	≤ 30 mA
Control output	NPN open collector output / PNP open collector output Model
Load voltage	≤ 26.4 VDC≡
Load current	≤ 100 mA
Residual voltage	NPN: ≤ 1 VDC≡, PNP: ≤ 2.5 VDC≡
Protection circuit	Reverse power protection circuit, output short overcurrent protection circuit
Insulation resistance	≥ 20 MΩ (500 VDC≡ megger)
Noise immunity	±240 VDC≡ the square wave noise (pulse width: 1 μs) by the noise simulator
Dielectric strength	Between the charging part and the case: 1,000 VAC~ 50/60 Hz for 1 min
Vibration resistance	1.5 mm double amplitude at frequency of 10 to 55 Hz in each X, Y, Z direction for 2 hours
Shock resistance	500 m/s ² (≈ 50 G) in each X, Y, Z direction for 3 times
Ambient illuminance (receiver)	Sunlight: ≤ 11,000 lx, incandescent lamp: ≤ 3,000 lx
Ambient temperature	-25 to 55 °C, storage: -40 to 70 °C (no freezing or condensation)
Ambient humidity	35 to 85 %RH, storage: 35 to 85 %RH (no freezing or condensation)
Protection rating	IP67 (IEC standard)
Connection	Connector type
Connector	M8 4-pin plug type
Material	Case: PC+ABS, CAP: PC, sensing part: PMMA, bracket: SUS304, bolt: SCM, nut: SCM, sleeve: Brass, Ni-plate

Sold Separately: Bracket A

- Unit: mm (Refer to the CAD files from the Autonics website for exact dimensions)

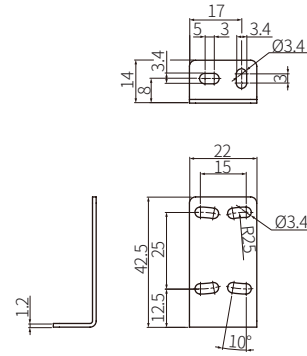





Sold Separately: M8 Connector Cable

- For detailed information, refer to the 'M8/M12 Connector Cable' manual.

Appearance	Power	Connector 1	Connector 2	Length	Feature	Model
	DC	M8 (Socket-Female) 4-pin	4-wire	2 m	PVC	CID408-2
				5 m		CID408-5
	DC	M8 (Socket-Female) 4-pin	4-wire	2 m	Oil resistant PVC	CIDH408-2
				5 m		CIDH408-5
	DC	M8 (Socket-Female) 4-pin, L type	4-wire	2 m	PVC	CLD408-2
				5 m		CLD408-5
	DC	M8 (Socket-Female) 4-pin, L type	4-wire	2 m	Oil resistant PVC	CLDH408-2
				5 m		CLDH408-5

Sold Separately: Reflector MS Series

Appearance	Size (W × H)	Reflectivity	Sensing type	Model
	40.5 × 60.5 mm	Typical reflectivity	Retroreflective	MS-2
		Typical reflectivity	Polarized retroreflective	MS-2A
		High reflectivity	Polarized retroreflective	MS-2S
	81.5 × 60.5 mm	Typical reflectivity	Retroreflective	MS-3
		High reflectivity	Polarized retroreflective	MS-3S
	29.3 × 38 mm	Typical reflectivity	Retroreflective	MS-4
	15.4 × 24 mm	Typical reflectivity	Retroreflective	MS-5
	13.7 × 23 mm	Typical reflectivity	Retroreflective	MS-6

- Material: PMMA / ABS (front part / rear part)
- Installation: Bolt mounting

■ Dimensions

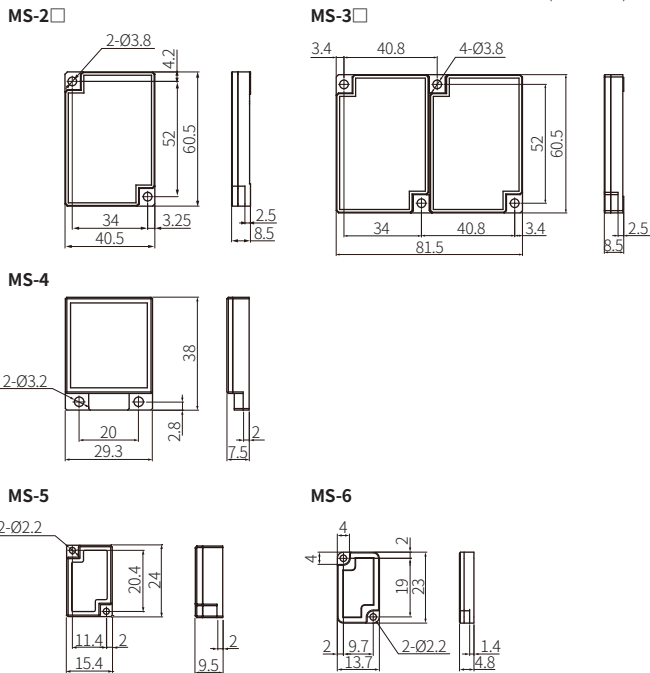

(Unit: mm)



■ Cautions During Installation

- Select a reflector size that is suitable for the installation space and operating environment of the sensors.
- In general, a bigger size of the reflector results in a longer sensing distance.
- Reflectors with high reflectivity increase the sensing distance compared to typical reflectors.
- The reflectance may vary depending on the operating environment for the sensors.

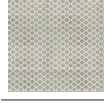
Sold Separately: Retroreflective Tape MST Series

Appearance	Size (W × H)	Approval	Packaged unit	Sensing type	Model
	50 × 50 mm	ERC	10	• Retroreflective • Polarized retroreflective	MST-50-10
	100 × 100 mm	ERC	5	• Retroreflective • Polarized retroreflective	MST-100-5
	200 × 200 mm	ERC	2	• Retroreflective • Polarized retroreflective	MST-200-2

- Material: PMMA / PC / Acrylic (surface film / prism layer / adhesive layer)
- Ambient temperature: -35 to 65 °C (temperature for adhesion: 10 to 30 °C)
- Installation: Tape cutting (installation distance: ≥ 20 mm)

■ Reflectance of MST Series

Series	Sensing type	MST-50-10	MST-100-5	MST-200-2
BTS	Retroreflective	95%	100%	100%
BM		70%	110%	170%
BMS		90%	120%	190%
BEN		90%	130%	140%
BX		90%	100%	110%
BJ	Polarized retroreflective	40%	60%	100%
BJR		35%	45%	55%
BJX		35%	45%	55%
BH		60%	80%	140%
BEN		70%	90%	120%
BX		30%	40%	60%
BRQ		40%	50%	80%
BRQP (plastic material type)		40%	80%	85%
BRQS (side sensing type)		25%	30%	35%

■ Dimensions

(Unit: mm)

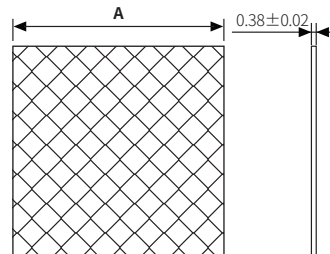

Model	A
MST-50-10	□ 50
MST-100-5	□ 100
MST-200-2	□ 200

■ Cautions During Installation

- Select a retroreflective tape that is suitable for the installation space and operating environment of the sensors.
- In general, a bigger size of retroreflective tape results in a longer sensing distance.
- Be sure to check the reflectance of the MST series for proper use.
- The reflectance may vary depending on the operating environment for the sensors.
- Before applying the tape, clean the adhesive side of the reflective tape with a dry cloth.
- Do not press or damage the surface of the retroreflective tape.
- Regularly clean the tape to maintain optimal performance, using only neutral detergents. Do not use chemical solvents.

Characteristic Curves: Through-beam Type

Sensing Area

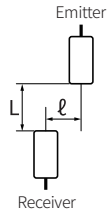

• BJ10M-TDT-C

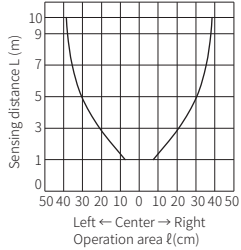

• BJ15M-TDT-C

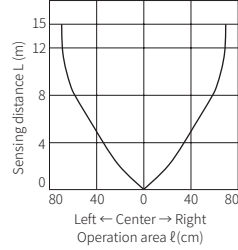

Emitter Angle

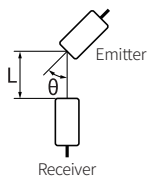

• BJ10M-TDT-C

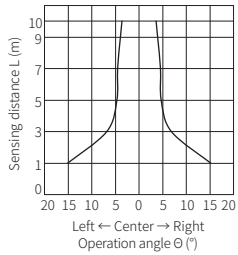

• BJ15M-TDT-C

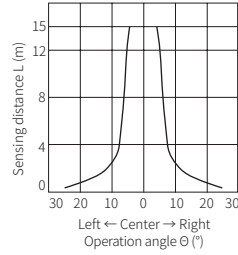

Characteristic Curves: Polarized Retroreflective Type

Sensing Area

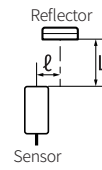

• BJ3M-PDT-C

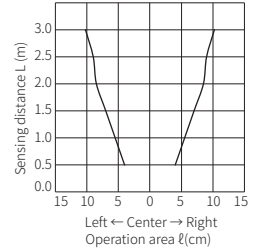

Sensor Angle

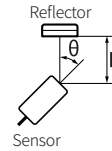

• BJ3M-PDT-C

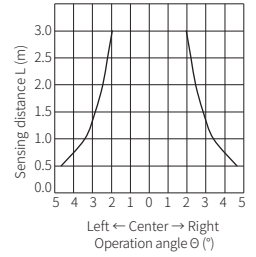

Reflector Angle

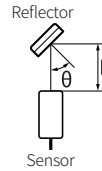

• BJ3M-PDT-C

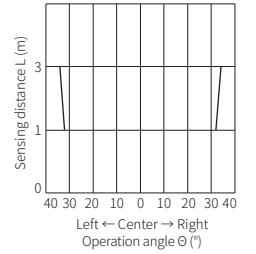

Characteristic Curves: Diffuse Reflective Type

Sensing Area

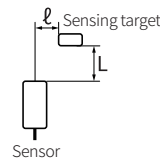

• BJ100-DDT-C

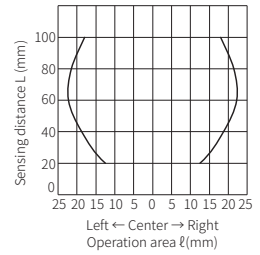

• BJ300-DDT-C

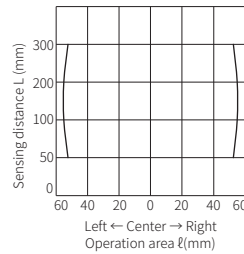

• BJ1M-DDT-C

